

# EQTG32D2DH-10.250M

[Click part number to visit Part Number Details page](#)

## REGULATORY COMPLIANCE (Data Sheet downloaded on Dec 12, 2019)

[Click badges to download compliance docs](#)

Regulatory Compliance standards are subject to updates by governing bodies. Click the badges to download the latest compliance docs for this part number directly from Ecliptek.



## ITEM DESCRIPTION

Temperature Compensated Quartz Crystal Clock Oscillators TCXO LVPECL (PECL) 2.5Vdc 6 Pad 2.5mm x 3.2mm Ceramic Surface Mount (SMD) 10.250MHz -10°C to +60°C

## ELECTRICAL SPECIFICATIONS

Nominal Frequency	10.250MHz
Frequency Stability	±5.0ppm Maximum (Inclusive of Operating Temperature Range, at Vdd=2.5Vdc)
Frequency Stability vs. Frequency Tolerance	±1.5ppm Maximum (at 25°C ±2°C, at Vdd=2.5Vdc, Pre-Reflow)
Frequency Stability vs. Input Voltage	±0.2ppm Maximum (±5%)
Frequency Stability vs. Load	±0.2ppm Maximum (±2pF)
Frequency Stability vs. Reflow	±1.0ppm Maximum (at 25°C, 24 hours after reflow, 1 time)
Frequency Stability vs. Aging	±1ppm/Year Maximum (at 25°C)
Operating Temperature Range	-10°C to +60°C
Supply Voltage	2.5Vdc ±5%
Input Current	75mA Maximum
Output Voltage Logic High (Voh)	Vdd-1.025Vdc Minimum, 1.6Vdc Typical, Vdd-0.6Vdc Maximum
Output Voltage Logic Low (Vol)	Vdd-1.85Vdc Minimum, 0.8Vdc Typical, Vdd-1.62Vdc Maximum
Rise/Fall Time	300pSec Maximum (Measured at 10% to 90% of Waveform)
Duty Cycle	50 ±5(%) (Measured at 50% of Waveform)
Load Drive Capability	50 Ohms into Vdd-2Vdc
Output Logic Type	LVPECL
Phase Noise	-64dBc/Hz at 10Hz offset; -96dBc/Hz at 100Hz offset; -124dBc/Hz at 1kHz offset; -131dBc/Hz at 10kHz offset; -132dBc/Hz at 100kHz offset; -149dBc/Hz at 1MHz offset; -157dBc/Hz at 10MHz offset; -159dBc/Hz at 20MHz offset (All Values are Typical)
Output Control Function	Output Enable (OE)
Output Control Input Voltage Logic High (Vih)	90% of Vdd Minimum or No Connect to Enable Output and Complementary Output
Output Control Input Voltage Logic Low (Vil)	10% of Vdd Maximum to Disable Output and Complementary Output (High Impedance)
Output Enable Time	100nSec Maximum
Output Disable Time	50nSec Maximum
Output Enable Current	15mA Maximum (Without Load (Pin 2 = Ground))
RMS Phase Jitter	1.5pSec Maximum (Fj=12kHz to 20MHz (Random))
Period Jitter (Deterministic)	0.2pSec Typical
Period Jitter (Random)	2pSec Typical
Period Jitter (RMS)	3pSec Maximum
Period Jitter (pk-pk)	30pSec Maximum
Start Up Time	10mSec Maximum
Storage Temperature Range	-55°C to +125°C

# EQTG32D2DH-10.250M

[Click part number to visit Part Number Details page](#)

## ENVIRONMENTAL & MECHANICAL SPECIFICATIONS

<b>ESD Susceptibility</b>	MIL-STD-883, Method 3015, Class 1, HBM: 1500V
<b>Fine Leak Test</b>	MIL-STD-883, Method 1014, Condition A
<b>Flammability</b>	UL94-V0
<b>Gross Leak Test</b>	MIL-STD-883, Method 1014, Condition C
<b>Mechanical Shock</b>	MIL-STD-883, Method 2002, Condition B
<b>Moisture Resistance</b>	MIL-STD-883, Method 1004
<b>Moisture Sensitivity</b>	J-STD-020, MSL 1
<b>Resistance to Soldering Heat</b>	MIL-STD-202, Method 210, Condition K
<b>Resistance to Solvents</b>	MIL-STD-202, Method 215
<b>Solderability</b>	MIL-STD-883, Method 2003
<b>Temperature Cycling</b>	MIL-STD-883, Method 1010, Condition B
<b>Vibration</b>	MIL-STD-883, Method 2007, Condition A

## EQTG32D2DH-10.250M [Click part number to visit Part Number Details page](#)

### MECHANICAL DIMENSIONS (all dimensions in millimeters)



PIN	CONNECTION
1	Do Not Connect
2	Output Enable (OE)
3	Case/Ground
4	Output
5	Complementary Output
6	Supply Voltage

LINE	MARKING
1	<b>E10.250</b> E=Ecliptek Designator
2	<b>XXXXX</b> XXXXX=Ecliptek Manufacturing Identifier

**Terminal Plating Thickness:** Gold (0.3 to 1.0µm) over Nickel (1.27 to 8.89µm).

### Suggested Solder Pad Layout

All Dimensions in Millimeters

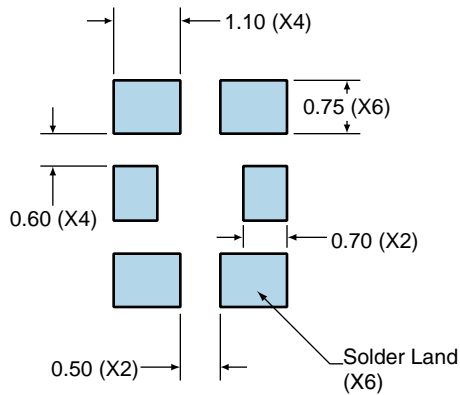

All Tolerances are ±0.1

# EQTG32D2DH-10.250M [Click part number to visit Part Number Details page](#)

## OUTPUT WAVEFORM & TIMING DIAGRAM

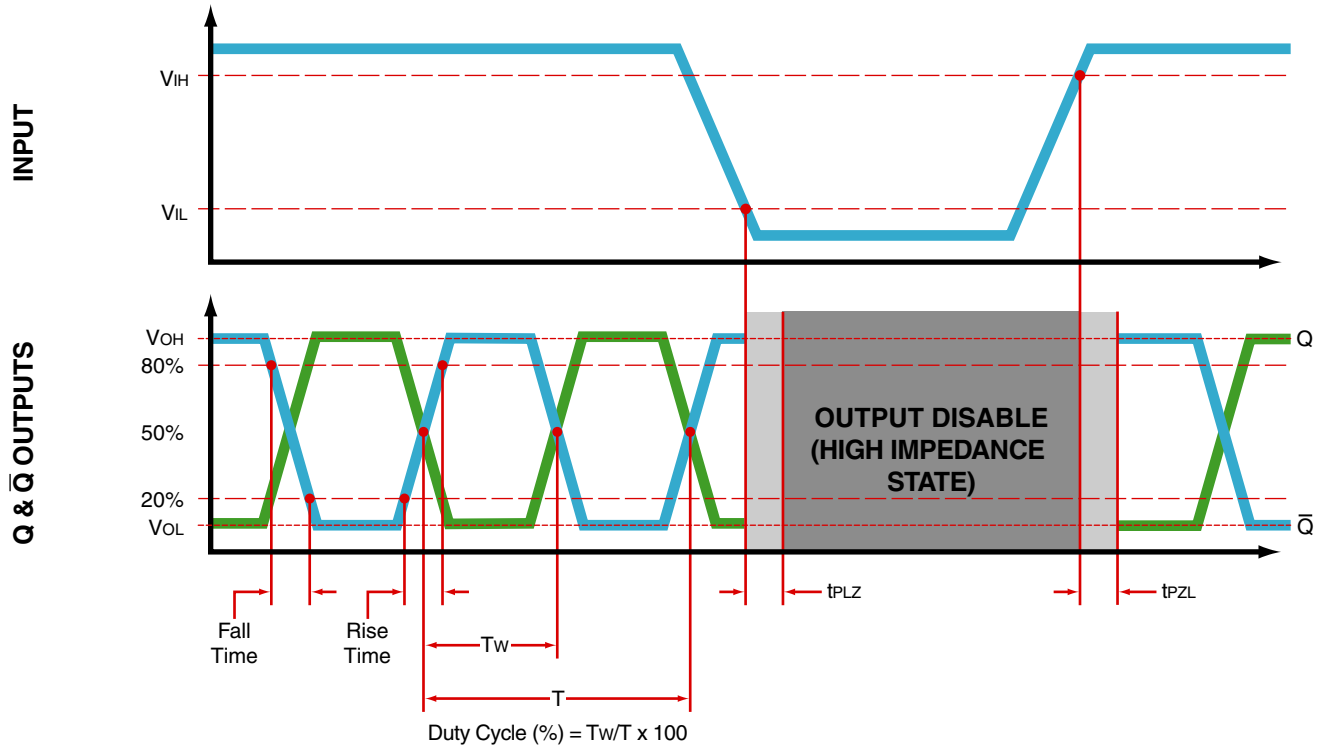

# EQTG32D2DH-10.250M

[Click part number to visit Part Number Details page](#)

## Test Circuit for PECL Output

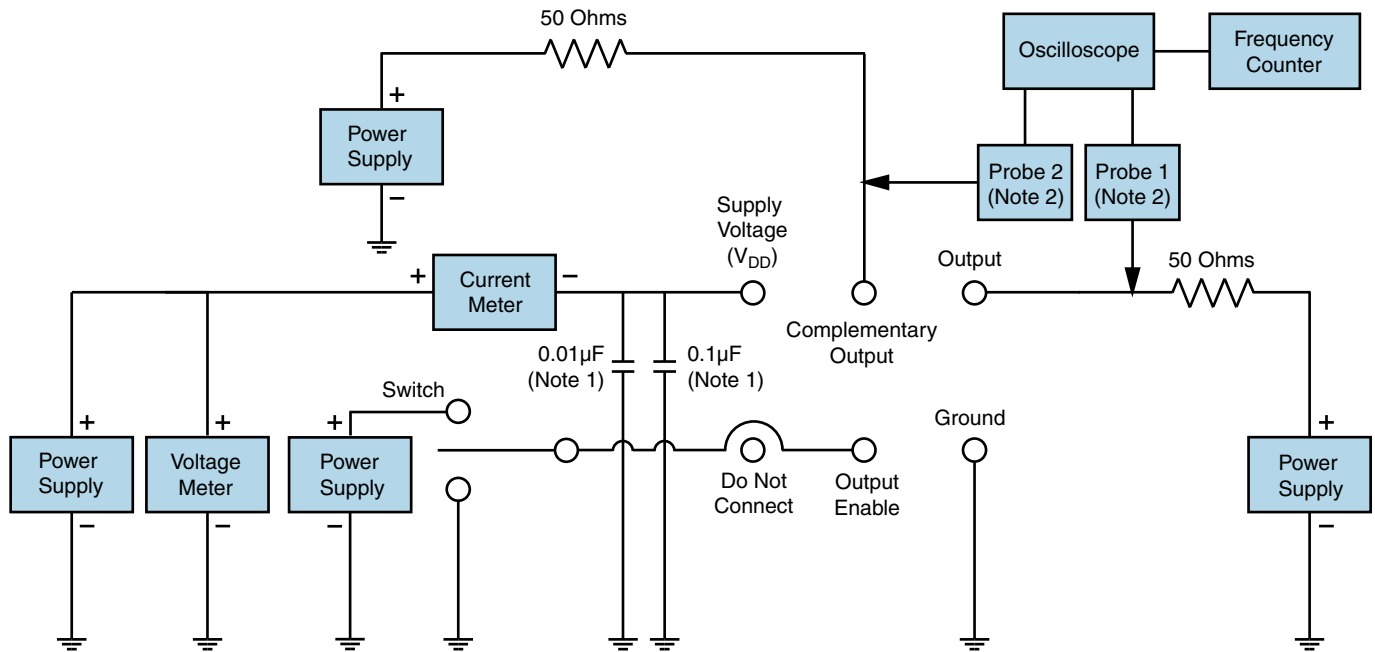

Note 1: An external 0.01  $\mu\text{F}$  ceramic bypass capacitor in parallel with a 0.1  $\mu\text{F}$  high frequency ceramic bypass capacitor close (less than 2mm) to the package ground and supply voltage pin is required.

Note 2: A low capacitance (<12pF), 10X attenuation factor, high impedance (>10Mohms), and high bandwidth (>500MHz) passive probe is recommended.

Note 3: Test circuit PCB traces need to be designed for a characteristic line impedance of 50 ohms.

# EQTG32D2DH-10.250M

[Click part number to visit Part Number Details page](#)

## Recommended Solder Reflow Methods



### High Temperature Infrared/Convection

$T_s \text{ MAX}$ to $T_L$ (Ramp-up Rate)	$3^\circ\text{C/Second Maximum}$
<b>Preheat</b>	
- Temperature Minimum ( $T_s \text{ MIN}$ )	$150^\circ\text{C}$
- Temperature Typical ( $T_s \text{ TYP}$ )	$175^\circ\text{C}$
- Temperature Maximum ( $T_s \text{ MAX}$ )	$200^\circ\text{C}$
- Time ( $t_s \text{ MIN}$ )	60 - 180 Seconds
<b>Ramp-up Rate (<math>T_L</math> to <math>T_P</math>)</b>	$3^\circ\text{C/Second Maximum}$
<b>Time Maintained Above:</b>	
- Temperature ( $T_L$ )	$217^\circ\text{C}$
- Time ( $t_L$ )	60 - 150 Seconds
<b>Peak Temperature (<math>T_P</math>)</b>	$260^\circ\text{C Maximum for 10 Seconds Maximum}$
<b>Target Peak Temperature (<math>T_P \text{ Target}</math>)</b>	$250^\circ\text{C} +0/-5^\circ\text{C}$
<b>Time within <math>5^\circ\text{C}</math> of actual peak (<math>t_p</math>)</b>	20 - 40 Seconds
<b>Ramp-down Rate</b>	$6^\circ\text{C/Second Maximum}$
<b>Time <math>25^\circ\text{C}</math> to Peak Temperature (t)</b>	8 Minutes Maximum
<b>Moisture Sensitivity Level</b>	Level 1
<b>Additional Notes</b>	Temperatures shown are applied to body of device.

# EQTG32D2DH-10.250M

[Click part number to visit Part Number Details page](#)

## Recommended Solder Reflow Methods



### Low Temperature Infrared/Convection 240°C

Ts MAX to TL (Ramp-up Rate)	5°C/Second Maximum
<b>Preheat</b>	
- Temperature Minimum (Ts MIN)	N/A
- Temperature Typical (Ts TYP)	150°C
- Temperature Maximum (Ts MAX)	N/A
- Time (ts MIN)	60 - 120 Seconds
<b>Ramp-up Rate (TL to TP)</b>	5°C/Second Maximum
<b>Time Maintained Above:</b>	
- Temperature (TL)	150°C
- Time (tL)	200 Seconds Maximum
<b>Peak Temperature (TP)</b>	240°C Maximum
<b>Target Peak Temperature (TP Target)</b>	240°C Maximum 2 Times / 230°C Maximum 1 Time
<b>Time within 5°C of actual peak (tp)</b>	10 Seconds Maximum 2 Times / 80 Seconds Maximum 1 Time
<b>Ramp-down Rate</b>	5°C/Second Maximum
<b>Time 25°C to Peak Temperature (t)</b>	N/A
<b>Moisture Sensitivity Level</b>	Level 1
<b>Additional Notes</b>	Temperatures shown are applied to body of device.

### Low Temperature Manual Soldering

185°C Maximum for 10 Seconds Maximum, 2 times Maximum. (Temperatures shown are applied to body of device.)

### High Temperature Manual Soldering

260°C Maximum for 5 Seconds Maximum, 2 times Maximum. (Temperatures shown are applied to body of device.)