

EQUB73E8H2-40.000M

[Click part number to visit Part Number Details page](#)

REGULATORY COMPLIANCE (Data Sheet downloaded on Jan 17, 2020)

[Click badges to download compliance docs](#)

Regulatory Compliance standards are subject to updates by governing bodies. Click the badges to download the latest compliance docs for this part number directly from Ecliptek.



ITEM DESCRIPTION

Temperature Compensated Voltage Controlled Quartz Crystal Clock Oscillators TCVCXO LVCMOS (CMOS) 3.3Vdc 14-Pin DIP Metal Thru-Hole 40.000MHz -40°C to +85°C

ELECTRICAL SPECIFICATIONS

Nominal Frequency	40.000MHz
Frequency Stability	±1.5ppm Maximum (Inclusive of Operating Temperature Range, at Vdd=3.3Vdc, at Vc=1.5V)
Frequency Stability vs. Frequency Tolerance	±2.0ppm Maximum (At 25°C ±2°C, at Vdd=3.3Vdc, at Vc=1.5V)
Frequency Stability vs. Input Voltage	±0.3ppm Maximum (±5%)
Frequency Stability vs. Load	±0.3ppm Maximum (±2pF)
Frequency Stability vs. Reflow	±1.0ppm Maximum (at 25°C, 1 hour after reflow, 1 times)
Aging at 25°C	±1ppm/Year Maximum
Operating Temperature Range	-40°C to +85°C
Supply Voltage	3.3Vdc ±5%
Input Current	20mA Maximum
Output Voltage Logic High (Voh)	90% of Vdd Minimum IOL=-4mA
Output Voltage Logic Low (Vol)	10% of Vdd Maximum IOL=+4mA
Rise/Fall Time	10nSec Maximum (Measured at 20% to 80% of waveform)
Duty Cycle	50 ±10(%) (Measured at 50% of waveform)
Load Drive Capability	15pF Maximum
Output Logic Type	CMOS
Control Voltage	1.5Vdc ±1.0Vdc
Frequency Deviation	±5ppm Minimum
Linearity	10% Maximum
Transfer Function	Positive Transfer Characteristic
Modulation Bandwidth	10kHz Minimum (Measured at -3dB)
Input Impedance	50kOhms Minimum
Phase Noise	-74dBc at 10Hz Offset, -105dBc at 100Hz Offset, -120dBc at 1kHz Offset, -124dBc at 10kHz Offset, -120dBc at 100kHz Offset (Typical Values)
Storage Temperature Range	-40°C to +85°C

ENVIRONMENTAL & MECHANICAL SPECIFICATIONS

Fine Leak Test	MIL-STD-883, Method 1014 Condition A
Gross Leak Test	MIL-STD-883, Method 1014 Condition C
Lead Integrity	MIL-STD-883, Method 2004
Mechanical Shock	MIL-STD-202, Method 213 Condition C
Resistance to Soldering Heat	MIL-STD-202, Method 210
Resistance to Solvents	MIL-STD-202, Method 215
Solderability	MIL-STD-883, Method 2003
Temperature Cycling	MIL-STD-883, Method 1010
Vibration	MIL-STD-883, Method 2007 Condition A

EQUB73E8H2-40.000M

[Click part number to visit Part Number Details page](#)

MECHANICAL DIMENSIONS (all dimensions in millimeters)

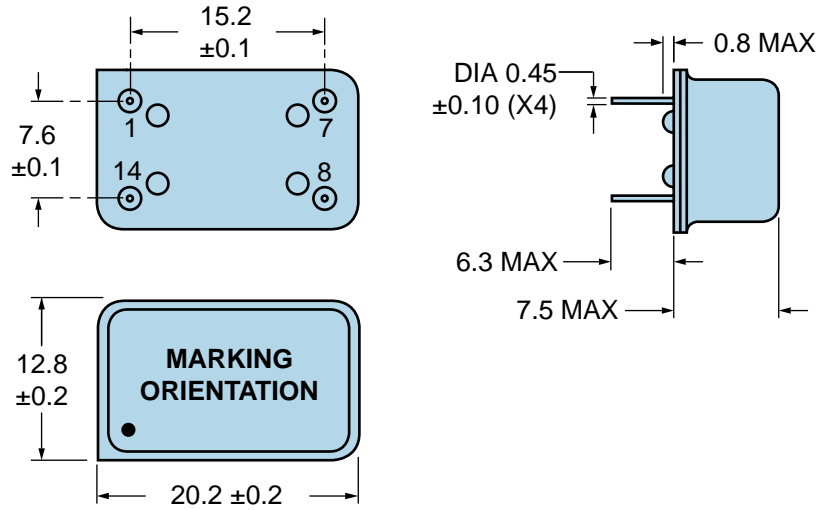

PIN	CONNECTION
1	Control Voltage
7	Case/Ground
8	Output
14	Supply Voltage

LINE	MARKING
1	ECLIPTEK
2	40.000M
3	XXXXX XXXXX=Ecliptek Manufacturing Identifier

EQUB73E8H2-40.000M [Click part number to visit Part Number Details page](#)

OUTPUT WAVEFORM

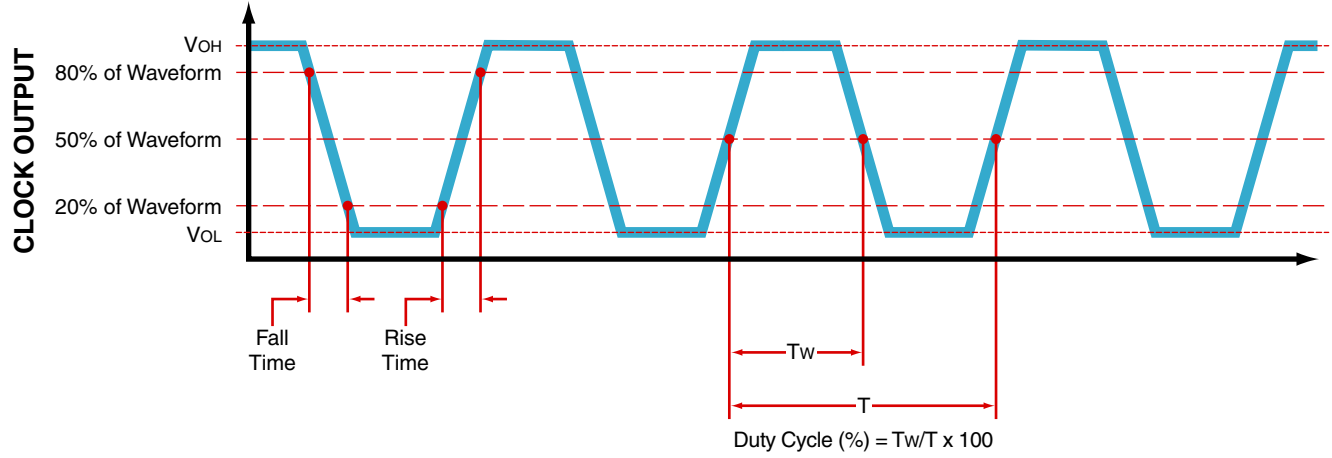

EQUB73E8H2-40.000M [Click part number to visit Part Number Details page](#)

Test Circuit for Voltage Control Option

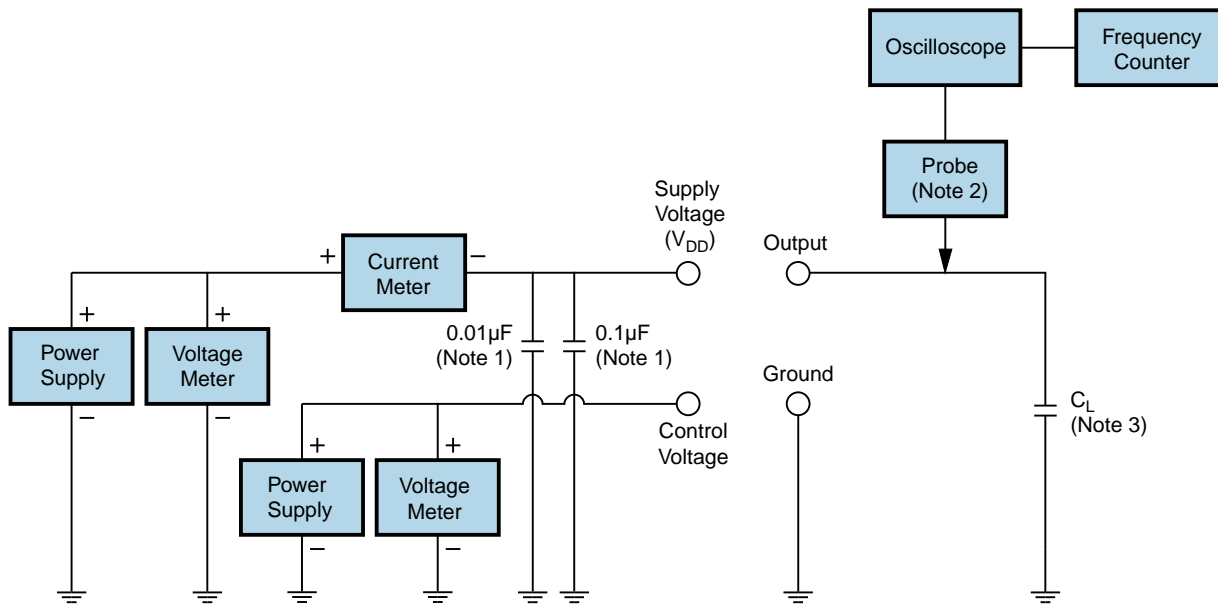

Note 1: An external $0.01\mu\text{F}$ ceramic bypass capacitor in parallel with a $0.1\mu\text{F}$ high frequency ceramic bypass capacitor close (less than 2mm) to the package ground and supply voltage pin is required.

Note 2: A low capacitance ($<12\text{pF}$), 10X attenuation factor, high impedance ($>10\text{Mohms}$), and high bandwidth ($>300\text{MHz}$) passive probe is recommended.

Note 3: Capacitance value C_L includes sum of all probe and fixture capacitance.

EQUB73E8H2-40.000M [Click part number to visit Part Number Details page](#)

Recommended Solder Reflow Methods



Low Temperature Solder Bath (Wave Solder)

Ts MAX to Tl (Ramp-up Rate)	5°C/Second Maximum
Preheat	
- Temperature Minimum (Ts MIN)	N/A
- Temperature Typical (Ts TYP)	150°C
- Temperature Maximum (Ts MAX)	N/A
- Time (ts MIN)	30 - 60 Seconds
Ramp-up Rate (Tl to Tp)	5°C/Second Maximum
Time Maintained Above:	
- Temperature (Tl)	150°C
- Time (tL)	200 Seconds Maximum
Peak Temperature (Tp)	245°C Maximum
Target Peak Temperature (Tp Target)	245°C Maximum 1 Time / 235°C Maximum 2 Times
Time within 5°C of actual peak (tp)	5 Seconds Maximum 1 Time / 15 Seconds Maximum 2 Times
Ramp-down Rate	5°C/Second Maximum
Time 25°C to Peak Temperature (t)	N/A
Moisture Sensitivity Level	Level 1

Low Temperature Manual Soldering

185°C Maximum for 10 Seconds Maximum, 2 times Maximum.

High Temperature Manual Soldering

260°C Maximum for 5 Seconds Maximum, 2 times Maximum.