

## Marketing Bulletin

**DATE:** January 28<sup>th</sup>, 2008  
**TO:** All Sales Personnel  
**FROM:** Isaac Gonzalez  
**RE:** Product Termination

To all concerned parties,

This bulletin is to notify all customers of the discontinuation of the following Ecliptek series effective January 28<sup>th</sup>, 2008:

<b>Series</b>	<b>Description</b>	<b>Recommended Replacement</b>
E3U	RoHS Compliant (Pb-free) Resistance Welded HC-49/UST Crystal	<a href="#">E2S Series</a>

In compliance with our End of Life (EOL) policy, this will serve as advanced notice of product termination. New orders will not be accepted after July 28<sup>th</sup>, 2008, with delivery to conclude by October 28<sup>th</sup>, 2008.

If there are any questions pertaining to this bulletin, please feel free to contact me. Thank you again for your cooperation.

Best Regards,



Isaac Gonzalez  
Configuration Manager  
Ecliptek Corporation

# E3U Series

- RoHS Compliant (Pb-Free)
- HC-49/UST package
- AT or BT cut available
- Resistance weld seal
- Tight tolerance/stability
- Insulator tab, and custom lead length options available

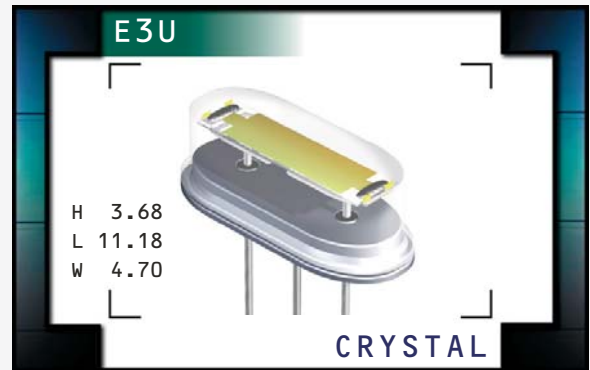

## NOTES

**OBSOLETE**

### ELECTRICAL SPECIFICATIONS

Frequency Range	3.579545MHz to 50.000MHz
Frequency Tolerance / Stability	±50ppm / ±100ppm (Standard), ±30ppm / ±50ppm (AT cut only), ±15ppm / ±30ppm (AT cut only),
Over Operating Temperature Range	±15ppm / ±20ppm (AT cut only), or ±10ppm / ±15ppm (AT cut only)
Operating Temperature Range	0°C to 70°C (Standard), -20°C to 70°C (AT cut only), or -40°C to 85°C (AT cut only)
Aging (at 25°C)	±5ppm / year Maximum
Storage Temperature Range	-40°C to 85°C
Shunt Capacitance	7pF Maximum
Insulation Resistance	500 Megaohms Minimum at 100V <sub>DC</sub>
Drive Level	1 mWatt Maximum
Load Capacitance (C <sub>L</sub> )	18pF (Standard), Custom C <sub>L</sub> ≥10pF, or Series Resonant
Drive Level Dependency (DLD2)	20% of Maximum ESR Limit (from 1μWatt to 1000μWatts)
Spurious Response	>3dB from F <sub>o</sub> to F <sub>o</sub> +5000ppm

### EQUIVALENT SERIES RESISTANCE (ESR), MODE OF OPERATION (MODE), AND CUT

Frequency Range	ESR (Ω)	Mode / Cut	Frequency Range	ESR (Ω)	Mode / Cut
3.579545MHz to 4.999MHz	200 Max	Fundamental / AT	15.000MHz to 15.999MHz	60 Max	Fundamental / AT
5.000MHz to 5.999MHz	150 Max	Fundamental / AT	16.000MHz to 23.999MHz	50 Max	Fundamental / AT
6.000MHz to 7.999MHz	120 Max	Fundamental / AT	24.000MHz to 29.4912MHz	40 Max	Fundamental / AT
8.000MHz to 8.999MHz	90 Max	Fundamental / AT	24.000MHz to 40.000MHz	40 Max	Fundamental / BT
9.000MHz to 9.999MHz	80 Max	Fundamental / AT	28.6363MHz to 29.999MHz	150 Max	Third Overtone / AT
10.000MHz to 14.999MHz	70 Max	Fundamental / AT	30.000MHz to 50.000MHz	100 Max	Third Overtone / AT

MANUFACTURER  
ECLIPTEK CORP.

CATEGORY  
CRYSTAL

SERIES  
E3U

PACKAGE  
HC-49/UST

CLASS  
CR45

REV. DATE  
03/04

## PART NUMBERING GUIDE

### E3U A A 18 - 30.000M - I2

#### FREQUENCY TOLERANCE / STABILITY

- A=±50ppm at 25°C, ±100ppm from 0°C to 70°C
- B=±50ppm at 25°C, ±100ppm from -20°C to 70°C
- C=±50ppm at 25°C, ±100ppm from -40°C to 85°C
- D=±30ppm at 25°C, ±50ppm from 0°C to 70°C
- E=±30ppm at 25°C, ±50ppm from -20°C to 70°C
- F=±30ppm at 25°C, ±50ppm from -40°C to 85°C
- G=±15ppm at 25°C, ±30ppm from 0°C to 70°C
- H=±15ppm at 25°C, ±30ppm from -20°C to 70°C
- J=±15ppm at 25°C, ±30ppm from -40°C to 85°C
- K=±15ppm at 25°C, ±20ppm from 0°C to 70°C
- L=±15ppm at 25°C, ±20ppm from -20°C to 70°C
- \* M=±15ppm at 25°C, ±20ppm from -40°C to 85°C
- \* N=±10ppm at 25°C, ±15ppm from 0°C to 70°C
- \* P=±10ppm at 25°C, ±15ppm from -20°C to 70°C

#### AVAILABLE OPTIONS

- Blank=None (Std)
- CD=Custom Lead Length (3.810 ±0.500mm)
- CE=Custom Lead Length (4.445 ±0.500mm)
- I2=Insulator Tab

#### FREQUENCY

#### LOAD CAPACITANCE

- S=Series
- XX=XXpF (Custom)

#### MODE OF OPERATION / CRYSTAL CUT

- A=Fundamental / AT
- B=Third Overtone / AT
- D=Fundamental / BT

\* Frequency Tolerance/Stability options M, N, and P are only available with frequencies greater than 10.000MHz

## NOTES

OBSOLETE

### MECHANICAL DIMENSIONS ALL DIMENSIONS IN MILLIMETERS

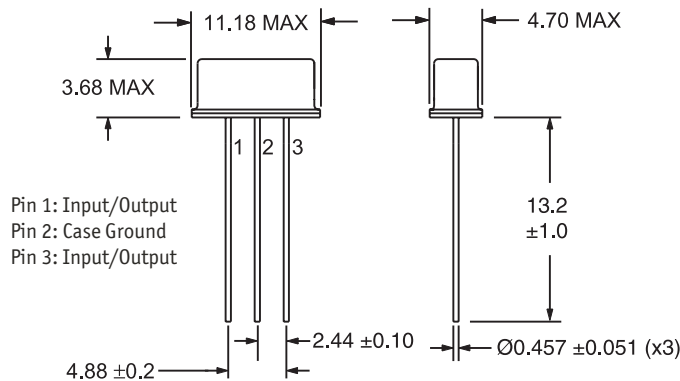

### ENVIRONMENTAL/MECHANICAL SPECIFICATIONS

#### PARAMETER

- Fine Leak Test
- Gross Leak Test
- Lead Integrity
- Lead Termination
- Mechanical Shock
- Resistance to Soldering Heat
- Resistance to Solvents
- Solderability
- Temperature Cycling
- Vibration

#### SPECIFICATION

- MIL-STD-883, Method 1014, Condition A
- MIL-STD-883, Method 1014, Condition C
- MIL-STD-883, Method 2004
- Sn 2µm - 6µm
- MIL-STD-202, Method 213, Condition C
- MIL-STD-202, Method 210
- MIL-STD-202, Method 215
- MIL-STD-883, Method 2002
- MIL-STD-883, Method 1010
- MIL-STD-883, Method 2007, Condition A

### MARKING SPECIFICATIONS

Line 1: E XX.XXX M  
Frequency in MHz  
 (5 Digits Maximum + Decimal)

MANUFACTURER  
ECLIPTEK CORP.

CATEGORY  
CRYSTAL

SERIES  
E3U

PACKAGE  
HC-49/UST

CLASS  
CR45

REV. DATE  
03/04