

Marketing Bulletin

DATE: July 28th, 2006
TO: All Sales Personnel
FROM: Isaac Gonzalez
RE: Product Termination

To all concerned parties,

This bulletin is to notify all customers of the discontinuation of the following Ecliptek series effective July 28th, 2006:

Series	Description	Recommended Replacement
E6WS	SMD Watch Crystal	<u>E8WS Series</u>

In compliance with our End of Life (EOL) policy, this will serve as advanced notice of product termination. New orders will not be accepted after September 31st, 2006, with delivery to conclude by December 31st, 2006.

If there are any questions pertaining to this bulletin, please feel free to contact me. Thank you again for your cooperation.

Best Regards,



Isaac Gonzalez
Configuration Manager
Ecliptek Corporation

E6WS Series



- RoHS Compliant (Pb-free)
- 32.768kHz watch crystal
- Miniature two pad surface mount package
- ± 20 ppm frequency tolerance
- 12.5pF load capacitance
- Tape and reel available

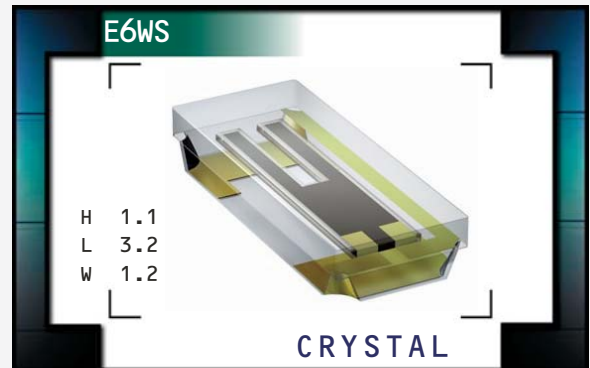

NOTES

OBSOLETE

ELECTRICAL SPECIFICATIONS

Frequency	32.768kHz
Frequency Tolerance (at 25°C)	± 20 ppm
Frequency Stability	-0.035ppm / $(\Delta^\circ\text{C})^2$ Maximum, Parabolic; Turn Over Temperature at 25°C $\pm 5^\circ\text{C}$
Operating Temperature Range	-40°C to 85°C
Aging (at 25°C)	± 3 ppm / year Maximum
Storage Temperature Range	-55°C to 125°C
Shunt Capacitance	1.7pF Typical, 2pF Maximum
Motional Capacitance	2.9fF Typical
Equivalent Series Resistance	65,000 Ohms Maximum
Insulation Resistance	500 Megaohms Minimum at 100V _{DC}
Drive Level	1 μ Watt Maximum
Load Capacitance (C _L)	12.5pF

MANUFACTURER
ECLIPTEK CORP.

CATEGORY
CRYSTAL

SERIES
E6WS

PACKAGE
GLASS

CLASS
CR54

REV. DATE
02/06

PART NUMBERING GUIDE

E6WSDC 12 - 32.768K TR

LOAD CAPACITANCE
12=12.5pF

PACKAGE OPTIONS
Blank=Bulk, TR=Tape and Reel

NOTES

OBSOLETE

MECHANICAL DIMENSIONS ALL DIMENSIONS IN MILLIMETERS

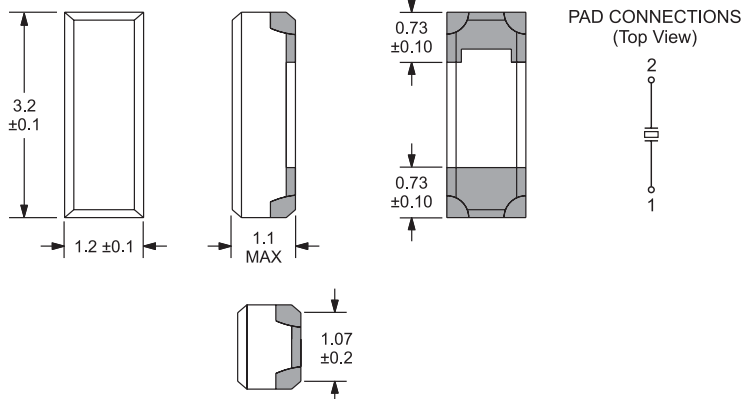

SUGGESTED SOLDER PAD LAYOUTS ALL DIMENSIONS IN MILLIMETERS

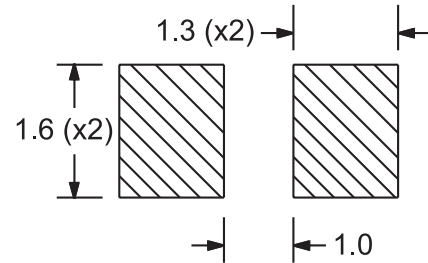

TAPE AND REEL DIMENSIONS ALL DIMENSIONS IN MILLIMETERS

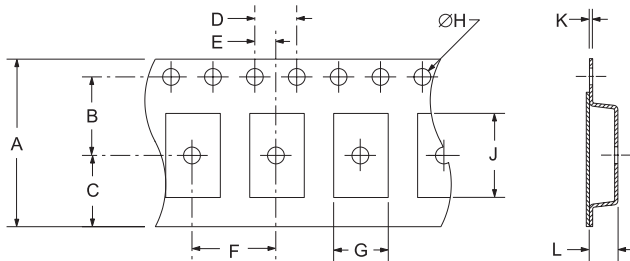

TAPE	A	B	C	D	E
	12±.3	5.5±.1	4.75±.1	4±.2	2±.1
	F	G	H	J	K
	8±.2	A0*	1.5±.1	B0*	.5±.05
				L	K0*

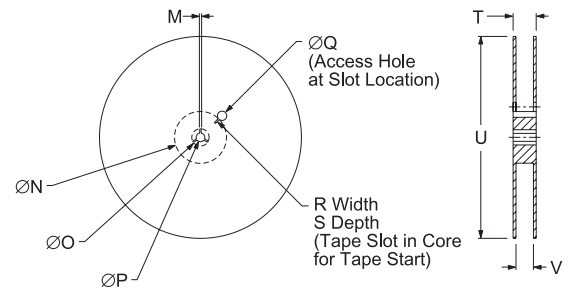

REEL	M	N	O	P	Q
	1.5 MIN	50 MIN	20.2 MIN	13±.5	40 MIN
	R	S	T	U	V
	2.5 MIN	10 MIN	18.4 MAX	180 MAX	12.4+2-0
					QTY/REEL
					3,000

*Compliant to EIA481A

PARABOLIC TEMPERATURE CURVE

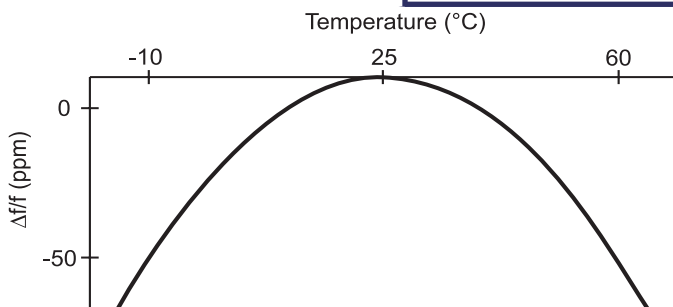

MARKING SPECIFICATIONS

Line 1: 32C XXXXX
 Lot Identifier (5 Characters MAX)
 Frequency Code

MANUFACTURER
ECLIPTEK CORP.

CATEGORY
CRYSTAL

SERIES
E6WS

PACKAGE
GLASS

CLASS
CR54

REV. DATE
02/06