

Marketing Bulletin

DATE: May 1st, 2008
TO: All Sales Personnel
FROM: Isaac Gonzalez
RE: Product Termination

To all concerned parties,

This bulletin is to notify all customers of the discontinuation of the following Ecliptek series effective May 1st, 2008:

Series	Description	Recommended Replacement
EC1	Resistance Welded Short HC-49/US Crystal	E1U Series

In compliance with our End of Life (EOL) policy, this will serve as advanced notice of product termination. New orders will not be accepted after September 1st, 2009, with delivery to conclude by December 31st, 2009.

If there are any questions pertaining to this bulletin, please feel free to contact me. Thank you again for your cooperation.

Best Regards,



Isaac Gonzalez
Configuration Manager
Ecliptek Corporation

EC1 Series

- HC-49/US short package
- AT or BT cut available
- Resistance weld seal
- Tight tolerance/stability
- Tape and reel, insulator tab, and custom lead length options available

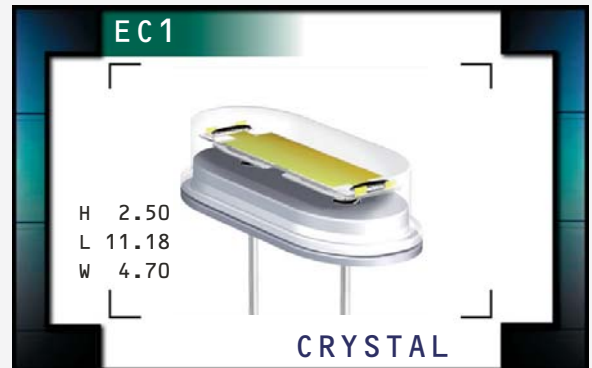

NOTES

ELECTRICAL SPECIFICATIONS

Frequency Range	3.579545MHz to 50.000MHz
Frequency Tolerance / Stability	±50ppm / ±100ppm (Standard), ±30ppm / ±50ppm (AT cut only), ±15ppm / ±30ppm (AT cut only),
Over Operating Temperature Range	±15ppm / ±20ppm (AT cut only), or ±10ppm / ±15ppm (AT cut only)
Operating Temperature Range	0°C to 70°C (Standard), -20°C to 70°C (AT cut only), or -40°C to 85°C (AT cut only)
Aging (at 25°C)	±5ppm / year Maximum
Storage Temperature Range	-40°C to 85°C
Shunt Capacitance	7pF Maximum
Insulation Resistance	500 Megaohms Minimum at 100V _{DC}
Drive Level	1 mWatt Maximum
Load Capacitance (C_L)	18pF (Standard), Custom C _L ≥10pF, or Series Resonant

EQUIVALENT SERIES RESISTANCE (ESR), MODE OF OPERATION (MODE), AND CUT

Frequency Range	ESR (Ω)	Mode / Cut	Frequency Range	ESR (Ω)	Mode / Cut
3.579545MHz to 4.999MHz	200 Max	Fundamental / AT	15.000MHz to 15.999MHz	60 Max	Fundamental / AT
5.000MHz to 5.999MHz	150 Max	Fundamental / AT	16.000MHz to 23.999MHz	50 Max	Fundamental / AT
6.000MHz to 7.999MHz	120 Max	Fundamental / AT	24.000MHz to 30.000MHz	40 Max	Fundamental / AT
8.000MHz to 8.999MHz	90 Max	Fundamental / AT	24.000MHz to 40.000MHz	40 Max	Fundamental / BT
9.000MHz to 9.999MHz	80 Max	Fundamental / AT	28.6363MHz to 29.999MHz	150 Max	Third Overtone / AT
10.000MHz to 14.999MHz	70 Max	Fundamental / AT	30.000MHz to 50.000MHz	100 Max	Third Overtone / AT

PART NUMBERING GUIDE

EC1 A - T - 20 - 30.000M - I2 TR

FREQUENCY TOLERANCE / STABILITY

Blank=±50ppm at 25°C, ±100ppm from 0°C to 70°C
 A=±50ppm at 25°C, ±100ppm from -20°C to 70°C
 B=±50ppm at 25°C, ±100ppm from -40°C to 85°C
 C=±30ppm at 25°C, ±50ppm from 0°C to 70°C
 D=±30ppm at 25°C, ±50ppm from -20°C to 70°C
 E=±30ppm at 25°C, ±50ppm from -40°C to 85°C
 F=±15ppm at 25°C, ±30ppm from 0°C to 70°C
 G=±15ppm at 25°C, ±30ppm from -20°C to 70°C
 H=±15ppm at 25°C, ±30ppm from -40°C to 85°C
 J=±15ppm at 25°C, ±20ppm from 0°C to 70°C
 K=±15ppm at 25°C, ±20ppm from -20°C to 70°C
 L=±15ppm at 25°C, ±20ppm from -40°C to 85°C
 M=±10ppm at 25°C, ±15ppm from 0°C to 70°C
 N=±10ppm at 25°C, ±15ppm from -20°C to 70°C

PACKAGING OPTIONS

Blank=Bulk, A=Tray, TR=Tape and Reel

AVAILABLE OPTIONS

Blank=None (Standard)
 CLXX=Custom Lead Length (See Page 42)
 I2=Insulator Tab (See Page 42)

FREQUENCY

LOAD CAPACITANCE

Blank=18pF (Standard), S=Series
 XX=XXpF (Custom)

MODE OF OPERATION / CRYSTAL CUT

Blank=Fundamental / AT
 B=Fundamental / BT
 T=Third Overtone / AT

MECHANICAL DIMENSIONS

ALL DIMENSIONS IN MILLIMETERS



TAPE AND REEL DIMENSIONS

ALL DIMENSIONS IN MILLIMETERS

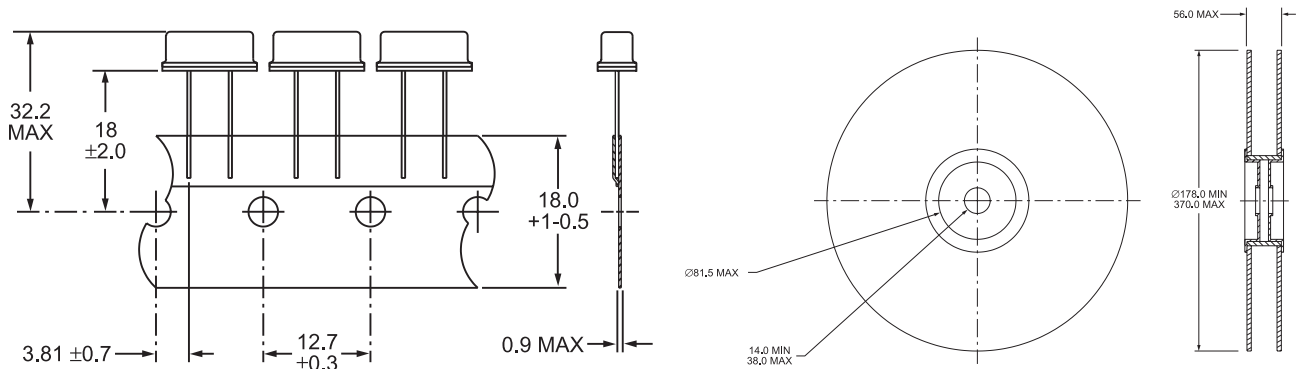

1000 Pieces per Reel
 Compliant to EIA-468B

ENVIRONMENTAL/MECHANICAL SPECIFICATIONS

PARAMETER	SPECIFICATION
Fine Leak Test	MIL-STD-883, Method 1014, Condition A
Gross Leak Test	MIL-STD-883, Method 1014, Condition C
Mechanical Shock	MIL-STD-202, Method 213, Condition C
Vibration	MIL-STD-883, Method 2007, Condition A
Lead Integrity	MIL-STD-883, Method 2004
Solderability	MIL-STD-883, Method 2002
Temperature Cycling	MIL-STD-883, Method 1010
Resistance to Soldering Heat	MIL-STD-883, Method 210
Resistance to Solvents	MIL-STD-883, Method 215

MARKING SPECIFICATIONS

Line 1: E XX.XXX M
 M or Blank (No Marking)
 Frequency in MHz
 (5 Digits Maximum + Decimal)

MANUFACTURER
 ECLIPTEK CORP.

CATEGORY
 CRYSTAL

SERIES
 EC1

PACKAGE
 HC-49/US Short

CLASS
 CR22

REV. DATE
 03/06