

Marketing Bulletin

DATE: August 19th, 2002
TO: Affected Customers
FROM: Marketing
RE: ES11F1, ES13F1, ES11W3 and ES13W3 Series
Termination

To all concerned parties,

This bulletin is to notify all customers of the termination of the following Ecliptek series effective August 19th, 2002:

Series	Description
ES11F1	14 pin DIP VCTCXO 5V
ES13F1	14 pin DIP VCTCXO 3.3V
ES11W3	9.6x11.8mm VCTCXO 5V
ES13W3	9.6x11.8mm VCTCXO 3.3V

Because of the circumstances surrounding this termination, there will be no end-of-life policy exercised. The series will be terminated with no purchasing or lifetime buy window available. All of us at Ecliptek Corporation apologize for any inconvenience this may have caused and can assure you we are taking measures to insure this will not happen in the future.

Best Regards,

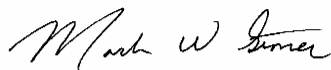

Mark W. Stoner
Director of Marketing
Ecliptek Corporation

STANDARD SPECIFICATIONS

Frequency Range:	10.000MHz to 26.000MHz
Frequency Stability:	See Table 1 for Maximum Values (Inclusive of Operating Temperature Range)
vs. Frequency Tolerance (25°C ±2°C)	±2.0ppm Maximum
vs. Input Voltage (±5%)	±0.3ppm Maximum
vs. Aging (at 25°C)	±1ppm/year Maximum
vs. Load (±1kΩ/±1pF)	±0.2ppm Maximum
Operating/Storage Temp. Range	See Table 1 for Operating Temperature Range / Storage -30°C to +85°C
Supply Voltage	5.0Vdc ±5%
Input Current	2.0mA Maximum
Output Voltage	1.0Vp-p Clipped Sinewave Minimum
Load Drive Capability	10kOhms // 10pF
Frequency Deviation (V Option Only)	±8ppm Minimum w/ Control Voltage of 1.5Vdc ±1.0Vdc; Positive Transfer Characteristic
Start Up Time	5mSec Maximum
Harmonics: 2nd Harmonic	-3dBc Maximum
3rd Harmonic	-6dBc Maximum
Other	-10dBc Maximum
Phase Noise (Typical)	-80dBc/Hz at 10Hz Offset -112dBc/Hz at 100Hz Offset -130dBc/Hz at 1kHz Offset -145dBc/Hz at 10kHz Offset

ENVIRONMENTAL & MECHANICAL

Shock:	Conditions and Criteria Listed in TQC41-883-007
Thermal Shock:	Conditions and Criteria Listed in TQC41-883-009
Seal Integrity:	Conditions and Criteria Listed in TQC41-883-003
Solderability:	Conditions and Criteria Listed in TQC41-883-004 / 95% coverage
Marking Permanency:	Conditions and Criteria Listed in TQC41-883-001

PART NUMBERING GUIDE

ES11F1 C 25 V - 12.800M - CL125

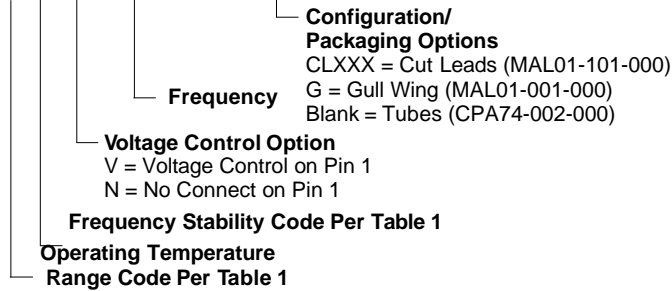

MARKING GUIDE

(Line #1) **ECLIPTEK**

(Line #2) **XX.XXXM**

Frequency

(Line #3) **XX Y ZZ** — Week of Year

Last Digit of Year

Ecliptek Manufacturing Code
(per TEN02-001-000)

NOTE: Pin 1 shall be marked with a dot.
Marking shall conform to conditions listed in TQC41-001-000.

OBSOLETE

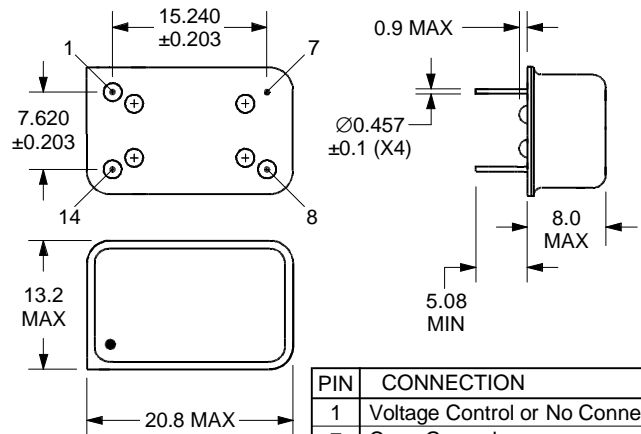

PIN	CONNECTION
1	Voltage Control or No Connect
7	Case Ground
8	Output
14	Supply Voltage

ALL DIMENSIONS
IN MILLIMETERS

SPECIFICATION CONTROL DRAWING

TABLE 1: PART NUMBERING CODES							ECLIPTEK [®] CORPORATION		Drawing Number CSC01-980-000		
OPERATING TEMPERATURE		FREQUENCY STABILITY X Denotes Availability For All Frequencies					Title 5.0V Full Size Metal 14-Pin DIP (VC)TCXO				
Range	Code	15	20	25	30	Code	Revision B				
		±1.5ppm	±2.0ppm	±2.5ppm	±3.0ppm	Range	Effectivity Date				
0°C to +50°C	A	X	X	X	X		ECN Number 6890				
-10°C to +60°C	B		X	X	X		PAGE 1 OF 2				
-20°C to +70°C	C		X	X	X		Approved By		Date		
-30°C to +60°C	D		X	X	X		Released By		Date		
-30°C to +75°C	E		X	X	X						
-30°C to +85°C	F			X	X						

STANDARD SPECIFICATIONS

Frequency Range:	10.000MHz to 26.000MHz
Frequency Stability:	See Table 1 for Maximum Values (Inclusive of Operating Temperature Range)
vs. Frequency Tolerance (25°C ±2°C)	±2.0ppm Maximum
vs. Input Voltage (±5%)	±0.3ppm Maximum
vs. Aging (at 25°C)	±1ppm/year Maximum
vs. Load (±1kΩ/±1pF)	±0.2ppm Maximum
Operating/Storage Temp. Range	See Table 1 for Operating Temperature Range / Storage -30°C to +85°C
Supply Voltage	3.0Vdc ±5%
Input Current	2.0mA Maximum
Output Voltage	0.7Vp-p Clipped Sinewave Minimum
Load Drive Capability	10kOhms // 10pF
Frequency Deviation (V Option Only)	±8ppm Minimum w/ Control Voltage of 1.5Vdc ±1.0Vdc; Positive Transfer Characteristic
Start Up Time	5mSec Maximum
Harmonics: 2nd Harmonic	-3dBc Maximum
3rd Harmonic	-6dBc Maximum
Other	-10dBc Maximum
Phase Noise (Typical)	-80dBc/Hz at 10Hz Offset -112dBc/Hz at 100Hz Offset -130dBc/Hz at 1kHz Offset -145dBc/Hz at 10kHz Offset

ENVIRONMENTAL & MECHANICAL

Shock:	Conditions and Criteria Listed in TQC41-883-007
Thermal Shock:	Conditions and Criteria Listed in TQC41-883-009
Seal Integrity:	Conditions and Criteria Listed in TQC41-883-003
Solderability:	Conditions and Criteria Listed in TQC41-883-004 / 95% coverage
Marking Permanency:	Conditions and Criteria Listed in TQC41-883-001

PART NUMBERING GUIDE

ES13F1 C 25 V - 12.800M - CL125

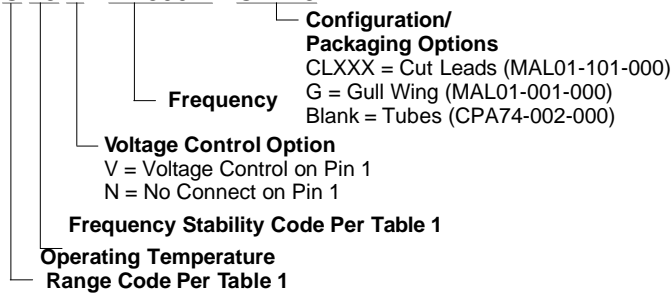

MARKING GUIDE

(Line #1) **ECLIPTEK**

(Line #2) **XX.XXXM**
Frequency

(Line #3) **XX Y ZZ** — Week of Year
Last Digit of Year
Ecliptek Manufacturing Code (per TEN02-001-000)

OBSOLETE

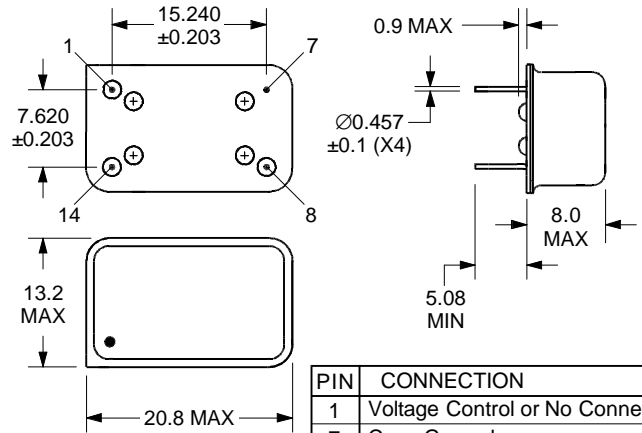

PIN	CONNECTION
1	Voltage Control or No Connect
7	Case Ground
8	Output
14	Supply Voltage

NOTE: Pin 1 shall be marked with a dot.
Marking shall conform to conditions listed in TQC41-001-000.

ALL DIMENSIONS
IN MILLIMETERS

SPECIFICATION CONTROL DRAWING

TABLE 1: PART NUMBERING CODES							ECLIPTEK [®] CORPORATION		Drawing Number CSC01-990-000		
OPERATING TEMPERATURE		FREQUENCY STABILITY X Denotes Availability For All Frequencies					Title 3.0V Full Size Metal 14-Pin DIP (VC)TCXO				
Range	Code	15	20	25	30	Code	Revision B				
		±1.5ppm	±2.0ppm	±2.5ppm	±3.0ppm	Range	Effectivity Date				
0°C to +50°C	A	X	X	X	X		ECN Number 6894				
-10°C to +60°C	B		X	X	X						
-20°C to +70°C	C		X	X	X						
-30°C to +60°C	D		X	X	X						
-30°C to +75°C	E		X	X	X						
-30°C to +85°C	F			X	X		PAGE 1 OF 2				
						Approved By		Date	Released By		Date

STANDARD SPECIFICATIONS

Frequency Range:	10.000MHz to 26.000MHz
Frequency Stability:	See Table 1 for Maximum Values (Inclusive of Operating Temperature Range)
vs. Frequency Tolerance (25°C ±2°C)	±2.0ppm Maximum
vs. Input Voltage (±5%)	±0.3ppm Maximum
vs. Aging (at 25°C)	±1ppm/year Maximum
vs. Load (±1kΩ/±1pF)	±0.2ppm Maximum
Operating/Storage Temp. Range	See Table 1 for Operating Temperature Range / Storage -30°C to +85°C
Supply Voltage	3.0Vdc ±5%
Input Current	2.0mA Maximum
Output Voltage	0.7Vp-p Clipped Sinewave Minimum
Load Drive Capability	10kOhms // 10pF
Frequency Deviation (V Option Only)	±8ppm Minimum w/ Control Voltage of 1.5Vdc ±1.0Vdc; Positive Transfer Characteristic
Start Up Time	5mSec Maximum
Harmonics: 2nd Harmonic	-3dBc Maximum
3rd Harmonic	-6dBc Maximum
Other	-10dBc Maximum
Phase Noise (Typical)	-80dBc/Hz at 10Hz Offset -112dBc/Hz at 100Hz Offset -130dBc/Hz at 1kHz Offset -145dBc/Hz at 10kHz Offset

ENVIRONMENTAL & MECHANICAL

Shock:	Conditions and Criteria Listed in TQC41-883-007
Vibration:	Conditions and Criteria Listed in TQC41-883-008

OBSOLETE

PART NUMBERING GUIDE

ES13W3 C 25 V - 12.800M TR – Packaging Options
 Blank = Bulk,
 TR = Tape & Reel
 CPA70-541-000

Frequency
 Voltage Control Option
 V = Voltage Control on Pin 1
 N = No Connect on Pin 1
 Frequency Stability Code Per Table 1
 Operating Temperature Range Code Per Table 1

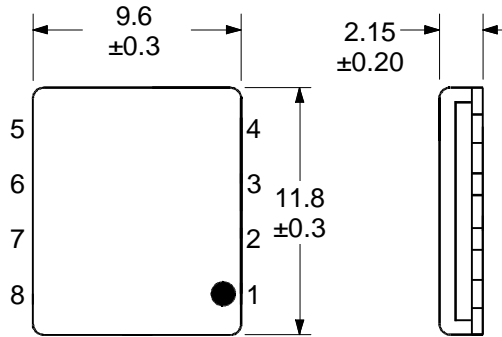

MARKING GUIDE

(Line #1) **ECLIPTEK**
 (Line #2) **XX.XXXM**
 Frequency
 (Line #3) **XX Y ZZ** – Week of Year
 Last Digit of Year
 Ecliptek Manufacturing Code (per TEN02-001-000)

NOTE: Pin 1 shall be marked with a dot.
 Marking shall conform to conditions listed in TQC41-001-000.

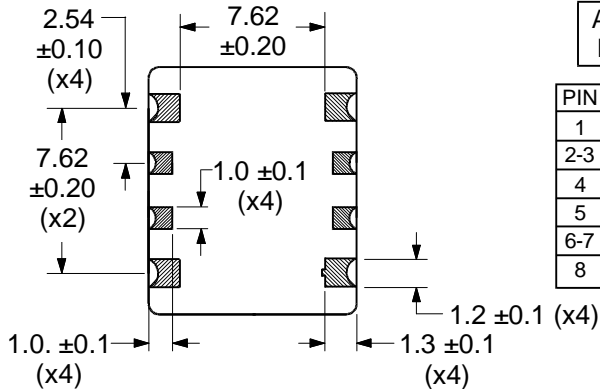

ALL DIMENSIONS IN MILLIMETERS

PIN	CONNECTION
1	Voltage Control or No Connect
2-3	No Connect
4	Ground
5	Output
6-7	No Connect
8	Supply Voltage

SPECIFICATION CONTROL DRAWING

TABLE 1: PART NUMBERING CODES							ECLIPTEK [®] CORPORATION		Drawing Number CSC23-970-000		
OPERATING TEMPERATURE		FREQUENCY STABILITY X Denotes Availability For All Frequencies					Title 3.0V PCB Surface Mount Sinewave (VC)TCXO				
Range	Code	15	20	25	30	Code	Revision B				
		±1.5ppm	±2.0ppm	±2.5ppm	±3.0ppm	Range	Effectivity Date				
0°C to +50°C	A	X	X	X	X		6895				
-10°C to +60°C	B		X	X	X						
-20°C to +70°C	C		X	X	X		PAGE 1 OF 2				
-30°C to +60°C	D		X	X	X						
-30°C to +75°C	E		X	X	X		Approved By _____ Date _____ Released By _____ Date _____				
-30°C to +85°C	F			X	X						

STANDARD SPECIFICATIONS

Frequency Range:	10.000MHz to 26.000MHz
Frequency Stability:	See Table 1 for Maximum Values (Inclusive of Operating Temperature Range)
vs. Frequency Tolerance (25°C ±2°C)	±2.0ppm Maximum
vs. Input Voltage (±5%)	±0.3ppm Maximum
vs. Aging (at 25°C)	±1ppm/year Maximum
vs. Load (±1kΩ/±1pF)	±0.2ppm Maximum
Operating/Storage Temp. Range	See Table 1 for Operating Temperature Range / Storage -30°C to +85°C
Supply Voltage	5.0Vdc ±5%
Input Current	2.0mA Maximum
Output Voltage	1.0Vp-p Clipped Sinewave Minimum
Load Drive Capability	10kOhms // 10pF
Frequency Deviation (V Option Only)	±8ppm Minimum w/ Control Voltage of 1.5Vdc ±1.0Vdc; Positive Transfer Characteristic
Start Up Time	5mSec Maximum
Harmonics: 2nd Harmonic	-3dBc Maximum
3rd Harmonic	-6dBc Maximum
Other	-10dBc Maximum
Phase Noise (Typical)	-80dBc/Hz at 10Hz Offset -112dBc/Hz at 100Hz Offset -130dBc/Hz at 1kHz Offset -145dBc/Hz at 10kHz Offset

ENVIRONMENTAL & MECHANICAL

Shock:	Conditions and Criteria Listed in TQC41-883-007
Vibration:	Conditions and Criteria Listed in TQC41-883-008

OBSOLETE

PART NUMBERING GUIDE

ES11W3 C 25 V - 12.800M TR – Packaging Options
Blank = Bulk,
TR = Tape & Reel
CPA70-541-000

Frequency
Voltage Control Option
V = Voltage Control on Pin 1
N = No Connect on Pin 1
Frequency Stability Code Per Table 1
Operating Temperature
Range Code Per Table 1

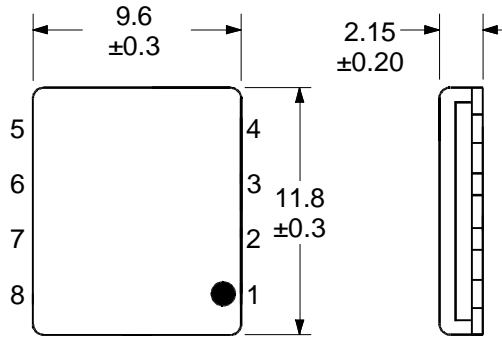

MARKING GUIDE

(Line #1) **ECLIPTEK**
(Line #2) **XX.XXXM** — Frequency
(Line #3) **XX Y ZZ** — Week of Year
Last Digit of Year
Ecliptek Manufacturing Code
(per TEN02-001-000)

NOTE: Pin 1 shall be marked with a dot.
Marking shall conform to conditions
listed in TQC41-001-000.

ALL DIMENSIONS
IN MILLIMETERS

PIN	CONNECTION
1	Voltage Control or No Connect
2-3	No Connect
4	Ground
5	Output
6-7	No Connect
8	Supply Voltage

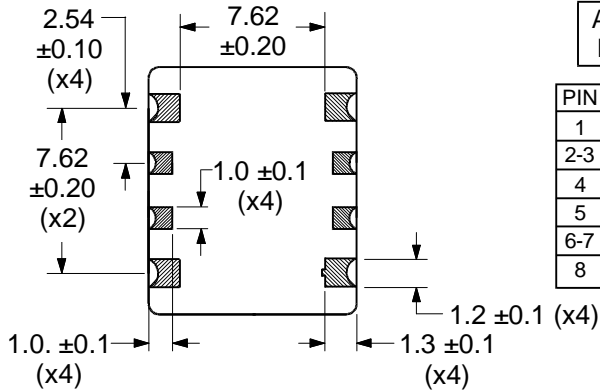

SPECIFICATION CONTROL DRAWING

TABLE 1: PART NUMBERING CODES							ECLIPTEK [®] CORPORATION		Drawing Number CSC23-960-000		
OPERATING TEMPERATURE		FREQUENCY STABILITY X Denotes Availability For All Frequencies					Title 5.0V PCB Surface Mount Sinewave (VC)TCXO				
Range	Code	15	20	25	30	Code	Revision B				
		±1.5ppm	±2.0ppm	±2.5ppm	±3.0ppm	Range	ECN Number 6891		Effectivity Date		
0°C to +50°C	A	X	X	X	X		PAGE 1 OF 2				
-10°C to +60°C	B		X	X	X						
-20°C to +70°C	C		X	X	X		Approved By		Date		
-30°C to +60°C	D		X	X	X						
-30°C to +75°C	E		X	X	X		Released By		Date		
-30°C to +85°C	F			X	X						