

Marketing Bulletin

DATE: August 5, 2005
TO: All Sales Personnel
FROM: Mark Stoner
RE: Product Termination

To all concerned parties,

This bulletin is to notify all customers of the discontinuation of the following Ecliptek series effective August 1st, 2005:

Series	Description	Recommended Replacement
ES52C8	3.3V SMD TCXO	ES52C1

In compliance with our End of Life (EOL) policy, this will serve as advanced notice of product termination. New orders will not be accepted after November 1st, 2005, with delivery to conclude by February 1st 2006.

If there are any questions pertaining to this bulletin, please feel free to contact me. Thank you again for your cooperation.

Best Regards,

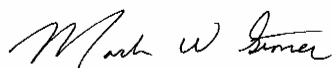

Mark W. Stoner
Director of Marketing
Ecliptek Corporation

STANDARD SPECIFICATIONS

Nominal Frequency	12.8MHz 13MHz 13.5625MHz 14.4MHz 16MHz 16.368MHz 18.432MHz 19.2MHz 20MHz 26MHz
Frequency Stability Vs. Frequency Tolerance	±0.5ppm Maximum (25°C ±2°C)
Frequency Stability	<i>Inclusive of Operating Temperature Range</i> ±1.5ppm Maximum (Only available with Operating Temperature Range of 0°C to +50°C) ±2.0ppm Maximum (Not available with Operating Temperature Range of -30°C to +85°C) ±2.5ppm Maximum ±3.0ppm Maximum
Frequency Stability vs. Input Voltage	±0.2ppm Maximum (±5%)
Frequency Stability vs. Load	±0.2ppm Maximum (±1kOhm//±1pF)
Frequency Stability vs. Aging	±1ppm/year Maximum (at 25°C)
Operating Temperature Range	0°C to +50°C -10°C to +60°C -20°C to +70°C -30°C to +60°C -30°C to +75°C -30°C to +85°C
Supply Voltage	3.00Vdc ±0.15Vdc
Input Current	2.0mA Maximum
Output Voltage	0.7Vp-p Clipped Sinewave Minimum
Load Drive Capability	10kOhms//10pF
Control Voltage	None (No Connect on Pin 1) 1.5Vdc ±1.0Vdc
Frequency Deviation	±8ppm Maximum, ±20ppm Maximum at Control Voltage of 1.5Vdc ±1.0Vdc
Transfer Function	Positive Transfer Characteristic at Control Voltage of 1.5Vdc ±1.0Vdc
Phase Noise	-80dBc/Hz Maximum at 10Hz Offset, -125dBc/Hz Maximum at 100Hz Offset, -145dBc/Hz Maximum at 1kHz Offset, -148dBc/Hz Maximum at 10kHz Offset, and -150dBc/Hz Maximum at 100kHz Offset
Harmonics	-3dBc Maximum at 2nd Harmonic, -6dBc Maximum at 3rd Harmonic, and -10dBc Maximum at other Harmonics
Start Up Time	5mSec Maximum
Storage Temperature Range	-40°C to +85°C

ENVIRONMENTAL & MECHANICAL

Fine Leak Test	MIL-STD-883, Method 1014 Condition A	Gross Leak Test	MIL-STD-883, Method 1014 Condition C
Mechanical Shock	MIL-STD-202, Method 213 Condition C	Resistance to Soldering Heat	MIL-STD-202, Method 210
Resistance to Solvents	MIL-STD-202, Method 215	Solderability	MIL-STD-883, Method 2002
Temperature Cycling	MIL-STD-883, Method 1010	Vibration	MIL-STD-883, Method 2007 Condition A

OBSOLETE

SPECIFICATION CONTROL DRAWING

	Drawing Number: CSC25-010-000
Title: Ecliptek Generic (ECLMF) ES52C8 Series	
Revision: B	Effectivity Date: 12-10-04
ECN Number: 10702	PAGE 1 OF 3
Approved By:	Released By:

PART NUMBERING GUIDE

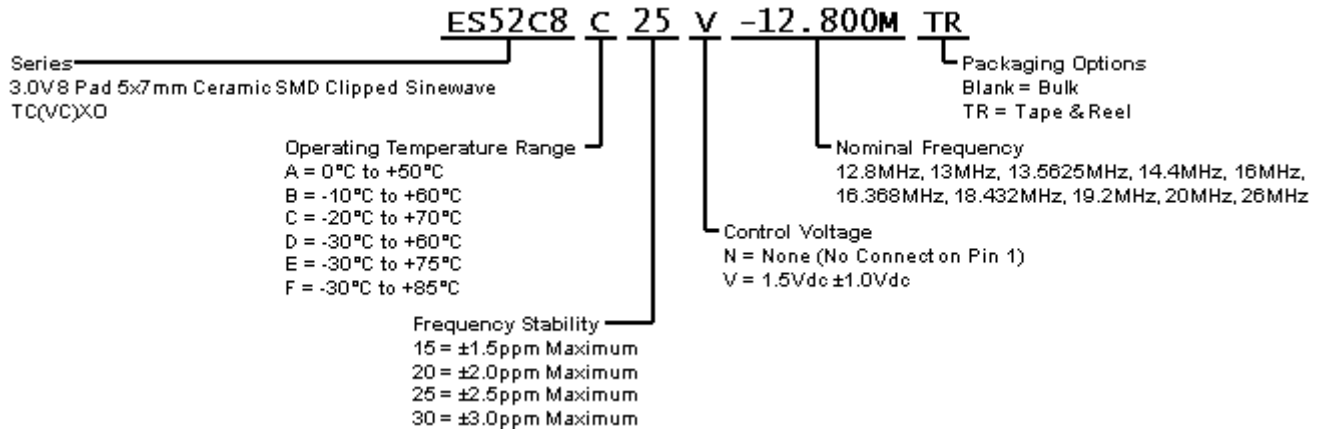

OBSOLETE

Pb-Free Status Information

Internal Pb Content	External Pb Content	Phase I	Phase II	Phase III	Pb-Free Status
>0.1% Pb	0% Pb	TBD	TBD	TBD	Not Pb-Free

Note: Please refer to TEN02-030-000 for Phase definitions. Phases marked with an X are deemed complete, otherwise phases are marked TBD (not available now).

SPECIFICATION CONTROL DRAWING

	Drawing Number: CSC25-010-000
	Title: Ecliptek Generic (ECLMF) ES52C8 Series
Revision: B	PAGE 2 OF 3

PHYSICAL DIMENSIONS

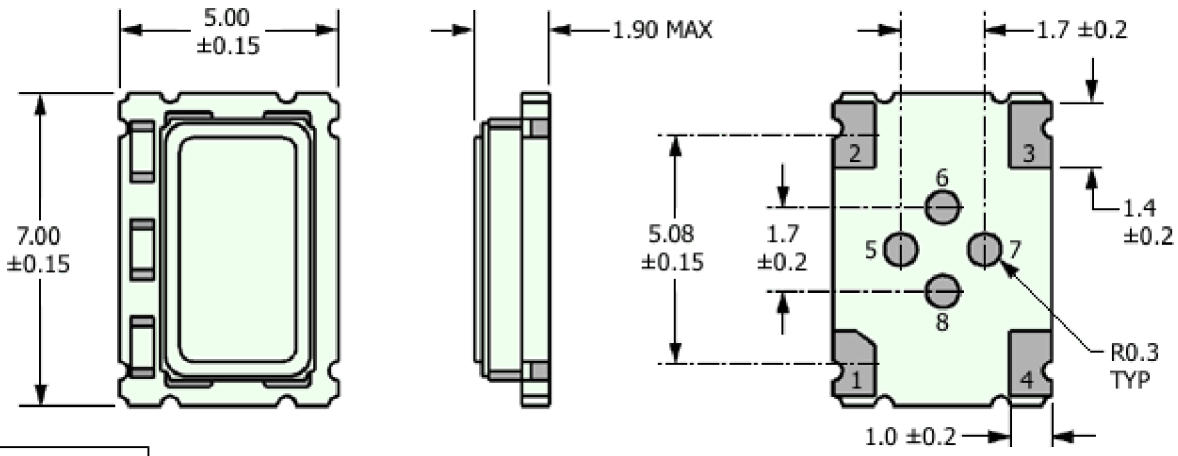

Pin	Connection
1	No Connect Or Voltage Control
2	Ground
3	Output
4	Supply Voltage
5	No Connect
6	No Connect
7	No Connect
8	No Connect

OBSOLETE

MARKING

- Line 1: **EXX.XXX**
 - E = Ecliptek Designator
 - XX.XXX = Nominal Frequency in MHz
- Line 2: **XXYZZ**
 - XX = Ecliptek Manufacturing Code
 - Y = Last Digit of the Year
 - ZZ = Week of the Year

NOTE: Marking shall conform to conditions listed in TQC41-001-000.

SPECIFICATION CONTROL DRAWING

	Drawing Number: CSC25-010-000
	Title: Ecliptek Generic (ECLMF) ES52C8 Series
Revision: B	PAGE 3 OF 3