

ECCM1 Series

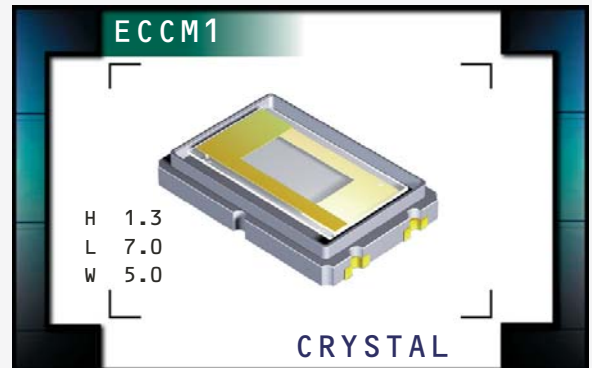

ECLIPTEK[®]
CORPORATION

- RoHS Compliant (Pb-Free)
- Four pad ceramic SMD package
- AT cut
- Tight tolerance/stability
- Frequencies to 70.000MHz available
- Tape and reel available



NOTES

ELECTRICAL SPECIFICATIONS

Frequency Range	7.680MHz to 70.000MHz
Frequency Tolerance / Stability	±50ppm / ±100ppm (Standard), ±30ppm / ±50ppm,
Over Operating Temperature Range	±15ppm / ±30ppm, ±15ppm / ±20ppm, or ±10ppm / ±15ppm
Operating Temperature Range	0°C to +70°C (Standard), -20°C to +70°C, or -40°C to +85°C
Aging (at 25°C)	±3ppm / year Maximum
Spurious Response	-3dB Minimum; F_0 to $F_0 + 5000$ ppm
Storage Temperature Range	-40°C to +85°C
Shunt Capacitance	7pF Maximum
Insulation Resistance	500 Megaohms Minimum at 100V _{DC}
Drive Level	50 µWatts Maximum, 50 µWatts Correlation
Load Capacitance (C_L)	18pF Parallel Resonant (Standard) Series Resonant 12pF Parallel Resonant to 50pF Resonant

EQUIVALENT SERIES RESISTANCE (ESR), MODE OF OPERATION (MODE), AND CUT

Frequency Range	ESR (Ω)	Mode / Cut	Frequency Range	ESR (Ω)	Mode / Cut
7.680MHz to 9.999MHz	90 Max	Fundamental / AT	16.000MHz to 24.999MHz	30 Max	Fundamental / AT
10.000MHz to 10.999MHz	60 Max	Fundamental / AT	25.000MHz to 40.000MHz	30 Max	Fundamental / AT
11.000MHz to 13.999MHz	50 Max	Fundamental / AT	36.000MHz to 39.999MHz	100 Max	Third Overtone / AT
14.000MHz to 15.999MHz	40 Max	Fundamental / AT	40.000MHz to 70.000MHz	80 Max	Third Overtone / AT

MANUFACTURER
ECLIPTEK CORP.

CATEGORY
CRYSTAL

SERIES
ECCM1

PACKAGE
CERAMIC

CLASS
CR08

REV. DATE
03/10

PART NUMBERING GUIDE

ECCM1 CT - 20 - 40.00M TR

FREQUENCY TOLERANCE / STABILITY

Blank=±50ppm at 25°C, ±100ppm from 0°C to +70°C
 A=±50ppm at 25°C, ±100ppm from -20°C to +70°C
 B=±50ppm at 25°C, ±100ppm from -40°C to +85°C
 C=±30ppm at 25°C, ±50ppm from 0°C to +70°C
 D=±30ppm at 25°C, ±50ppm from -20°C to +70°C
 E=±30ppm at 25°C, ±50ppm from -40°C to +85°C
 F=±15ppm at 25°C, ±30ppm from 0°C to +70°C
 G=±15ppm at 25°C, ±30ppm from -20°C to +70°C
 H=±15ppm at 25°C, ±30ppm from -40°C to +85°C
 J=±15ppm at 25°C, ±20ppm from 0°C to +70°C
 K=±15ppm at 25°C, ±20ppm from -20°C to +70°C
 L=±15ppm at 25°C, ±20ppm from -40°C to +85°C
 M=±10ppm at 25°C, ±15ppm from 0°C to +70°C
 N=±10ppm at 25°C, ±15ppm from -20°C to +70°C
 *P=±10ppm at 25°C, ±15ppm from -40°C to +85°C

PACKAGING OPTIONS

Blank=Bulk, TR=Tape and Reel

FREQUENCY

LOAD CAPACITANCE

Blank=18pF (Standard)
 S=Series Resonant
 XX=12pF Parallel Resonant to 50pF Parallel Resonant

MODE OF OPERATION / CRYSTAL CUT

Blank=Fundamental / AT, T=Third Overtone / AT

MECHANICAL DIMENSIONS

ALL DIMENSIONS IN MILLIMETERS

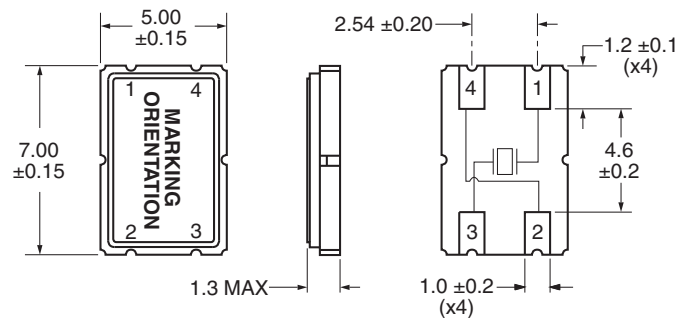

*Available only from 7.680MHz to 27.000MHz

Note: Chamfer and index mark not shown.

Pad 1: Input/Output Pad 3: Input/Output
 Pad 2: Cover/Ground Pad 4: Cover/Ground

SUGGESTED SOLDER PAD LAYOUT

ALL DIMENSIONS IN MILLIMETERS

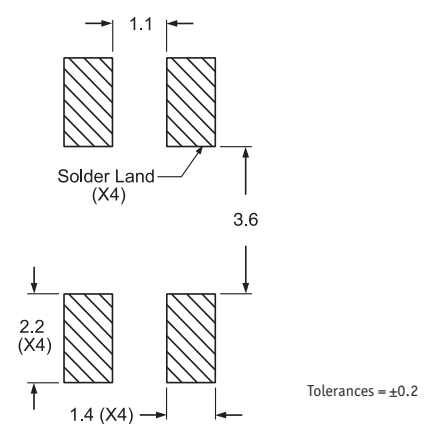

TAPE AND REEL DIMENSIONS

ALL DIMENSIONS IN MILLIMETERS

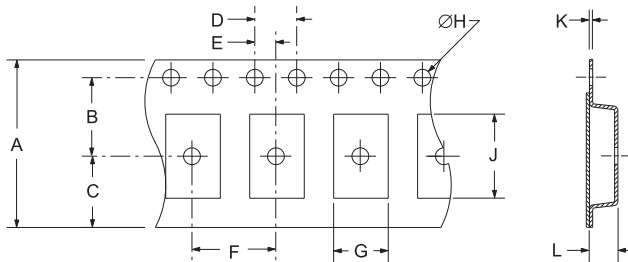

TAPE	A	B	C	D	E	
	16±.3	7.5±.2	6.75±.2	4±.2	2±.2	
F	G	H	J	K	L	
	8±.2	5.4±.1	1.5±.1	7.9±.1	.3±.05	1.7±.1

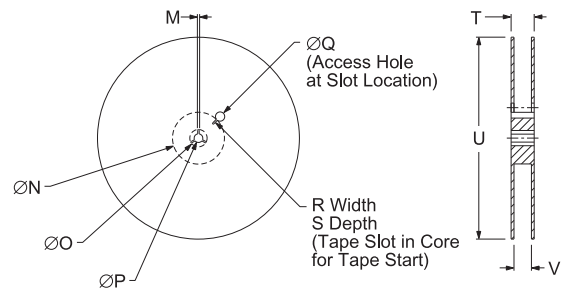

REEL	M	N	O	P	Q	
	1.5 MIN	50 MIN	20.2 MIN	13±.2	40 MIN	
R	S	T	U	V	QTY/REEL	
	2.5 MIN	10 MIN	22.4 MAX	360 MAX	16,4+2-0	3,000

ENVIRONMENTAL/MECHANICAL SPECIFICATIONS

PARAMETER

ESD Susceptibility
 Fine Leak Test
 Gross Leak Test
 Flammability
 Mechanical Shock
 Moisture Resistance
 Moisture Sensitivity
 Resistance to Soldering Heat
 Resistance Solvents
 Solderability
 Temperature Cycling
 Vibration

SPECIFICATION

MIL-STD-883, Method 3015, Class 1, HBM: 1500V
 MIL-STD-883, Method 1014, Condition A
 MIL-STD-883, Method 1014, Condition C
 UL94-V0
 MIL-STD-883, Method 2002, Condition B
 MIL-STD-883, Method 1004
 J-STD-020, MSL 1
 MIL-STD-202, Method 210, Condition K
 MIL-STD-202, Method 215
 MIL-STD-883, Method 2003
 MIL-STD-883, Method 1010, Condition B
 MIL-STD-883, Method 2007, Condition A

MARKING SPECIFICATIONS

*Compliant to EIA-481A

Line 1: E XX.XX
 Frequency in MHz
 (4 Digits Maximum + Decimal)

Line 2: XXXXX
 Ecliptek Manufacturing Identifier

MANUFACTURER
 ECLIPTEK CORP.

CATEGORY
 CRYSTAL

SERIES
 ECCM1

PACKAGE
 CERAMIC

CLASS
 CR08

REV. DATE
 03/10