

EB13C3 Series



ECLIPTEK[®]
CORPORATION

- Crystal Clock Oscillators
- LVCMOS Output
- +3.3V Supply Voltage
- Tri-State Output Function
- Low Stand-by Current
- Low Input Current
- 4 Pad Ceramic SMD Package



ELECTRICAL SPECIFICATIONS

Frequency Range		6.144MHz to 40.000MHz
Operating Temperature Range		0°C to +70°C -40°C to +85°C
Storage Temperature Range		-55°C to +125°C
Supply Voltage (V_{DD})		3.3V _{DC} ±10%
Input Current	6.144MHz to 10.000MHz	2mA Maximum
	10.001MHz to 20.000MHz	3mA Maximum
	20.001MHz to 36.000MHz	5mA Maximum
	36.001MHz to 40.000MHz	6mA Maximum
Frequency Tolerance / Stability	Inclusive of all conditions: Calibration Tolerance at 25°C, Frequency Stability over the Operating Temperature Range, Supply Voltage Change, Output Load Change, First Year Aging at 25°C, Shock, and Vibration	±100ppm, ±50ppm, ±25ppm or ±20ppm Max.
Output Voltage Logic High (V_{OH})	I _{OH} = -4mA	90% of V _{DD} Minimum
Output Voltage Logic Low (V_{OL})	I _{OL} = +4mA	10% of V _{DD} Maximum
Rise / Fall Time	≤25.000MHz 20% to 80% of Waveform	6nSeconds Maximum
	>25.000MHz 20% to 80% of Waveform	4nSeconds Maximum
Duty Cycle	at 50% of Waveform	50 ±10(%) (Standard)
	at 50% of Waveform	50 ±5(%) (Optional)
Load Drive Capability		15pF Maximum
Tri-State Input Voltage	No Connection	Enables Output
	V _{IH} : ≥90% of V _{DD}	Enables Output
	V _{IL} : ≤10% of V _{DD}	Disables Output: High Impedance
Standby Current	Disabled Output: High Impedance	10µA Maximum
RMS Phase Jitter	12kHz to 20MHz offset frequency	1pSec Maximum
Period Jitter	Deterministic	0.2pSec Typical, 3pSec Maximum
	Random	2pSec Typical, 5pSec Maximum
	RMS	3pSec Typical, 7pSec Maximum
	pk-pk	40pSec Typical, 100pSec Maximum
Start Up Time		10 mSeconds Maximum

MANUFACTURER
ECLIPTEK CORP.

CATEGORY
OSCILLATOR

SERIES
EB13C3

PACKAGE
CERAMIC

VOLTAGE
3.3V

CLASS
OS11

REV. DATE
09/10

PART NUMBERING GUIDE

EB13C3 F 2 H - 40.000M TR

FREQUENCY TOLERANCE / STABILITY

C = ±100ppm Maximum over 0°C to +70°C
 D = ±50ppm Maximum over 0°C to +70°C
 E = ±25ppm Maximum over 0°C to +70°C
 F = ±20ppm Maximum over 0°C to +70°C
 G = ±100ppm Maximum over -40°C to +85°C
 H = ±50ppm Maximum over -40°C to +85°C
 J = ±25ppm Maximum over -40°C to +85°C
 K = ±20ppm Maximum over -40°C to +85°C

PACKAGING OPTIONS

Blank = Bulk, TR = Tape & Reel

FREQUENCY

OUTPUT CONTROL FUNCTION

H = Tri-State

DUTY CYCLE

1 = 50 ±10(%)
 2 = 50 ±5(%)

MECHANICAL DIMENSIONS

ALL DIMENSIONS IN MILLIMETERS

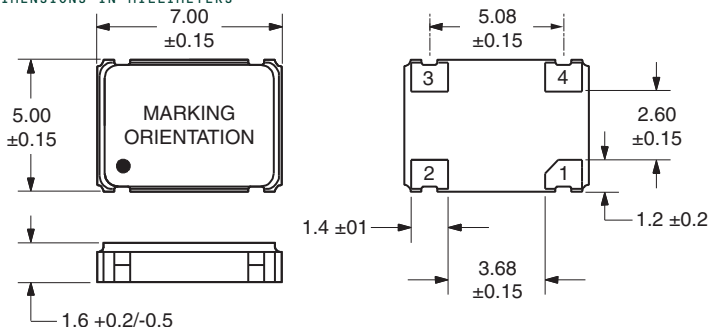

Pin 1: Tri-State
 Pin 2: Case Ground
 Pin 3: Output
 Pin 4: Supply Voltage

SUGGESTED SOLDER PAD LAYOUT

ALL DIMENSIONS IN MILLIMETERS

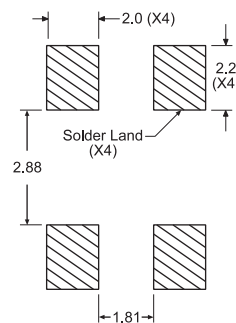

Tolerances = ±0.1

TAPE AND REEL DIMENSIONS

ALL DIMENSIONS IN MILLIMETERS

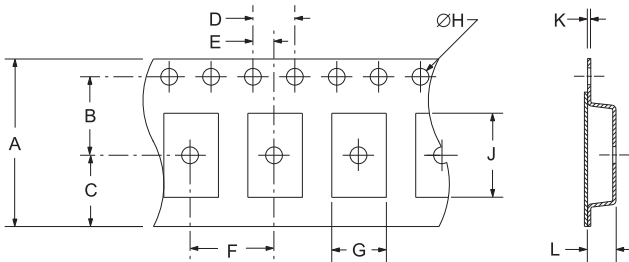

TAPE	A	B	C	D	E
	16+3-.1	7.5±.1	6.75±.1	4±.1	2±.1
	F	G	H	J	K
	8±.1	B0*	1.5+1-0	A0*	.3±.05
				L	K0*

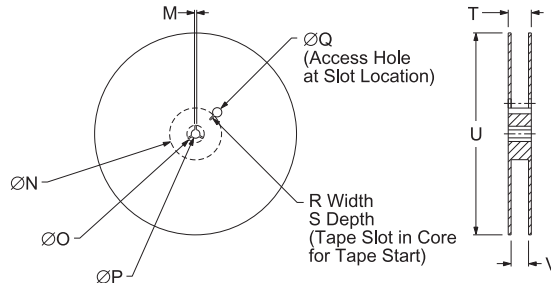

REEL	M	N	O	P	Q
	1.5 MIN	50 MIN	20.2 MIN	13±.2	40 MIN
	R	S	T	U	V
	2.5 MIN	10 MIN	22.4 MAX	360 MAX	16.4+2-0
					QTY/REEL
					1,000

*Compliant to EIA 481A

ENVIRONMENTAL/MECHANICAL SPECIFICATIONS

Characteristic	Specification
ESD Susceptibility	MIL-STD-883, Method 3015, Class 1, HBM: 1500V
Fine Leak Test	MIL-STD-883, Method 1014, Condition A
Flammability	UL94-V0
Gross Leak test	MIL-STD-883, Method 1014, Condition C
Mechanical Shock	MIL-STD-883, Method 2002, Condition B
Moisture Resistance	MIL-STD-883, Method 1004
Moisture Sensitivity	J-STD-020, MSL 1
Resistance to Soldering Heat	MIL-STD-202, Method 210, Condition K
Resistance to Solvents	MIL-STD-202, Method 215
Solderability	MIL-STD-883, Method 2003
Temperature Cycling	MIL-STD-883, Method 1010, Condition B
Vibration	MIL-STD-883, Method 2007, Condition A

MARKING SPECIFICATIONS

Line 1: ECLIPTEK
 Line 2: XX.XXX M
 Frequency in MHz (5 Digits Maximum + Decimal)
 Line 3: XX Y ZZ
 Week of Year
 Last Digit of Year
 Ecliptek Manufacturing Identifier

MANUFACTURER	CATEGORY	SERIES	PACKAGE	VOLTAGE	CLASS	REV. DATE
ECLIPTEK CORP.	OSCILLATOR	EB13C3	CERAMIC	3.3V	OS1I	09/10