

Marketing Bulletin

DATE: April 20th, 2010
TO: All Sales Personnel
FROM: Isaac Gonzalez
RE: Product Termination

To all concerned parties,

This bulletin is to notify all customers of the discontinuation of the following Ecliptek series effective April 20th, 2010:

Series	Description	Recommended Replacement
EC11	RoHS Compliant (Pb-free) 5.0V 14 Pin DIP Metal Thru-Hole HCMOS/TTL Oscillator	EH11
EC11HS	RoHS Compliant (Pb-free) 5.0V 8 Pin DIP Metal Thru-Hole HCMOS/TTL Oscillator	EH11HS

In compliance with our End of Life (EOL) policy, this will serve as advanced notice of product termination. New orders will not be accepted after September 1st, 2010, with delivery to conclude by December 1st, 2010.

If there are any questions pertaining to this bulletin, please feel free to contact me. Thank you again for your cooperation.

Best Regards,

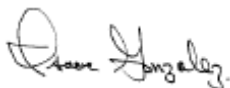

Isaac Gonzalez
Configuration Manager
Ecliptek Corporation

EC11 Series



- Crystal Clock Oscillators
- CMOS/TTL Output
- +5.0V Supply Voltage
- Tri-State Output Option
- Custom Lead Length & Gull Wing Options
- 8 pin DIP Metal Package
- RoHS Compliant (Pb-free)

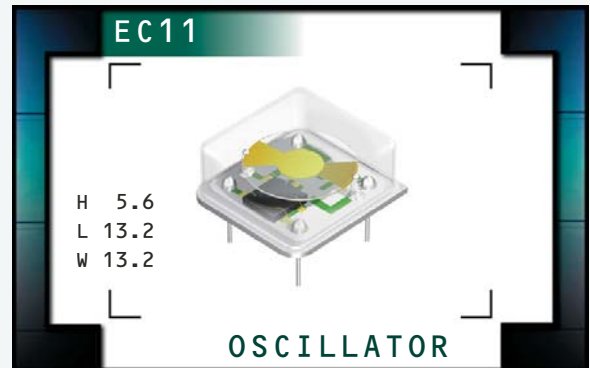

ELECTRICAL SPECIFICATIONS

Frequency Range (MHz)		0.250MHz to 106.250MHz
Operating Temperature Range		0°C to 70°C or -40°C to 85°C
Storage Temperature Range		-55°C to 125°C
Supply Voltage (V_{DD})		5.0V _{DC} ±10%
Input Current	250.000kHz to 24.000MHz	45mA Maximum
	24.001MHz to 50.000MHz	55mA Maximum
	50.001MHz to 66.667MHz	65mA Maximum
	66.668MHz to 106.250MHz	85mA Maximum
Frequency Tolerance / Stability	Inclusive of Operating Temperature Range, Supply Voltage, and Load	±100ppm, ±50ppm, ±25ppm, or ±20ppm Max. (0°C to 70°C Only)
Output Voltage Logic High (V_{OH})	w/TTL Load	2.4V _{DC} Minimum
	w/CMOS Load	V _{DD} -0.5V _{DC} Minimum
Output Voltage Logic Low (V_{OL})	w/TTL Load	0.4V _{DC} Maximum
	w/CMOS Load	0.5V _{DC} Maximum
Rise Time / Fall Time	0.4V _{DC} to 2.4V _{DC} w/TTL Load; 20% to 80% of Waveform w/CMOS Load	6 nSeconds Maximum
Duty Cycle	at 1.4V _{DC} w/TTL Load; at 50% of Waveform w/CMOS Load	50 ±10(%) (Standard)
	at 1.4V _{DC} w/TTL Load or w/CMOS Load ≤ 70.000MHz	50 ±5(%) (Optional)
	at 50% of Waveform w/TTL Load or w/CMOS Load > 70.000MHz	50 ±5(%) (Optional)
Load Drive Capability	250.000kHz to 24.000MHz	10TTL Load or 50pF CMOS Load
	24.001MHz to 70.000MHz	10TTL Load or 15pF CMOS Load
	70.001MHz to 106.250MHz	10LSTTL Load or 15pF CMOS Load
Tri-State Input Voltage	V _{IH} : No Connection	Enables Output
	V _{IH} : ≥2.2V _{DC}	Enables Output
	V _{IL} : ≤0.8V _{DC}	Disables Output: High Impedance
Aging (at 25°C)		±5ppm / year Maximum
Start Up Time		10mSeconds Maximum
Period Jitter: Absolute		±100pSeconds Maximum
Period Jitter: One Sigma		±25pSeconds Maximum

MANUFACTURER	CATEGORY	SERIES	PACKAGE	VOLTAGE	CLASS	REV. DATE
ECLIPTEK CORP.	OSCILLATOR	EC11	8 pin DIP	5.0V	OS05	08/06

PART NUMBERING GUIDE

EC11 00 HS ETTS - 60.000M - G TR

FREQUENCY TOLERANCE / STABILITY

00=±100ppm Max., 45=±50ppm Max.
25=±25ppm Max., 20=±20ppm Max.

PACKAGE

HS=Half Size 8 Pin DIP

OPERATING TEMP. RANGE

Blank=0°C to 70°C, ET=-40°C to 85°C

DUTY CYCLE

Blank=50 ±10(%), T=50 ±5(%)

OUTPUT CONTROL FUNCTION

Blank=None (No Connection on Pin 1), TS=Tri-State Enable High

PACKAGING OPTIONS

Blank=Bulk
TR=Tape & Reel (only offered with
Half Size G and Half Size G2 Options)

AVAILABLE OPTIONS

Blank=None
CLXXX=Custom Lead Length
G=Half Size Gull Wing
G2=Half Size Gull Wing

FREQUENCY

K=kHz, M=MHz

MECHANICAL DIMENSIONS ALL DIMENSIONS IN MILLIMETERS

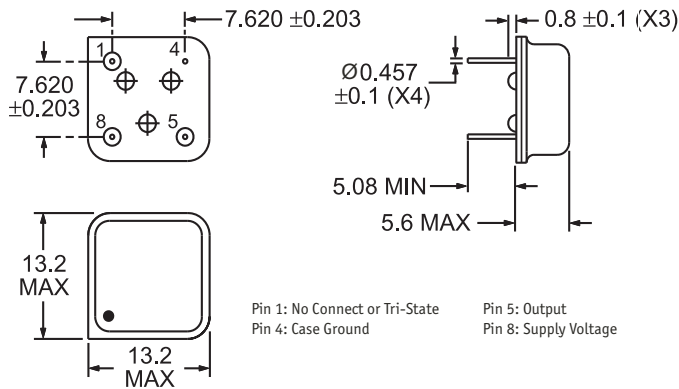

TAPE AND REEL DIMENSIONS ALL DIMENSIONS IN MILLIMETERS

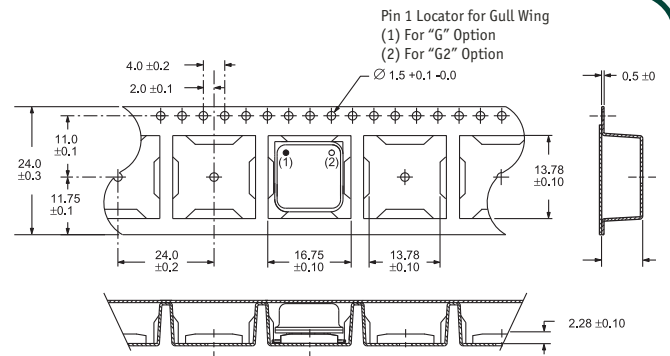

MARKING SPECIFICATIONS

Line 1: ECLIPTEK

Line 2: EC11 TS

Output Control Function
Blank = None (No Connection on Pin 1)
TS = Tri-State Enable High

Series Designator

Line 3: XX.XXX M

M=MHz, K=kHz

Frequency (5 Digits Maximum + Decimal)

Line 4: XX Y ZZ

Week of Year

Last Digit of Year

Ecliptek Manufacturing Identifier

Note: Pin 1 shall be designated with a dot

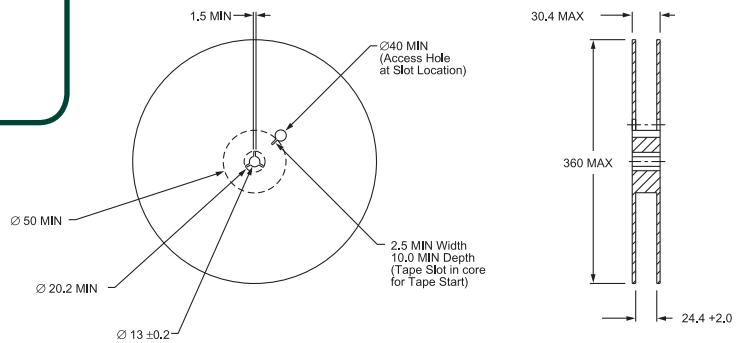

700 Pieces Per Reel
Compliant to EIA-481A

ENVIRONMENTAL/MECHANICAL SPECIFICATIONS

Characteristic	Specification
Fine Leak Test	MIL-STD-883, Method 1014, Condition A
Gross Leak Test	MIL-STD-883, Method 1014, Condition C
Mechanical Shock	MIL-STD-202, Method 213, Condition C
Vibration	MIL-STD-883, Method 2007, Condition A
Lead Integrity	MIL-STD-883, Method 2004
Solderability	MIL-STD-883, Method 2002
Temperature Cycling	MIL-STD-883, Method 1010
Resistance to Soldering Heat	MIL-STD-883, Method 210
Resistance to Solvents	MIL-STD-883, Method 215

MANUFACTURER	CATEGORY	SERIES	PACKAGE	VOLTAGE	CLASS	REV. DATE
ECLIPTEK CORP.	OSCILLATOR	EC11	8 pin DIP	5.0V	OS05	08/06